

iC-HT DUAL CW LASER DIODE DRIVER

Rev C1, Page 1/46

FEATURES

- ◆ Dual channel CW operation with up to 750 mA per channel
- ◆ Up to 1500 mA with both channels combined
- ◆ 2.8V to 11V power supply
- ◆ Operation with or without μ Controller
- ◆ Individual enable input per channel
- ◆ Control loop accuracy better than 1%
- ◆ Internal programmable logarithmic monitor resistor
- ◆ Operating point setup with 10 bit logarithmic resolution
- ◆ ACC or APC mode individually configurable for each channel
- ◆ A/D converters for analog monitoring
- ◆ Serial programming interface (SPI or I²C compliant)
- ◆ Configuration content verification and validation
- ◆ Programmable laser overcurrent protection
- ◆ Optimized for N-type laser diodes
- ◆ Low drop linear regulator for 3.3V
- ◆ Low current standby mode
- ◆ Temperature monitor
- ◆ Temperature range -40 ... 85 °C

APPLICATIONS

- ◆ Laser diode and LED modules
- ◆ CW N-/M-type laser diode drivers
- ◆ Embedded laser diode controllers
- ◆ Structured-light 3D illuminations
- ◆ Multiple laser diode control
- ◆ Optical amplification/pumping
- ◆ Safety related laser controllers

PACKAGES

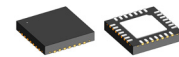

QFN28 5 mm x 5 mm

BLOCK DIAGRAM

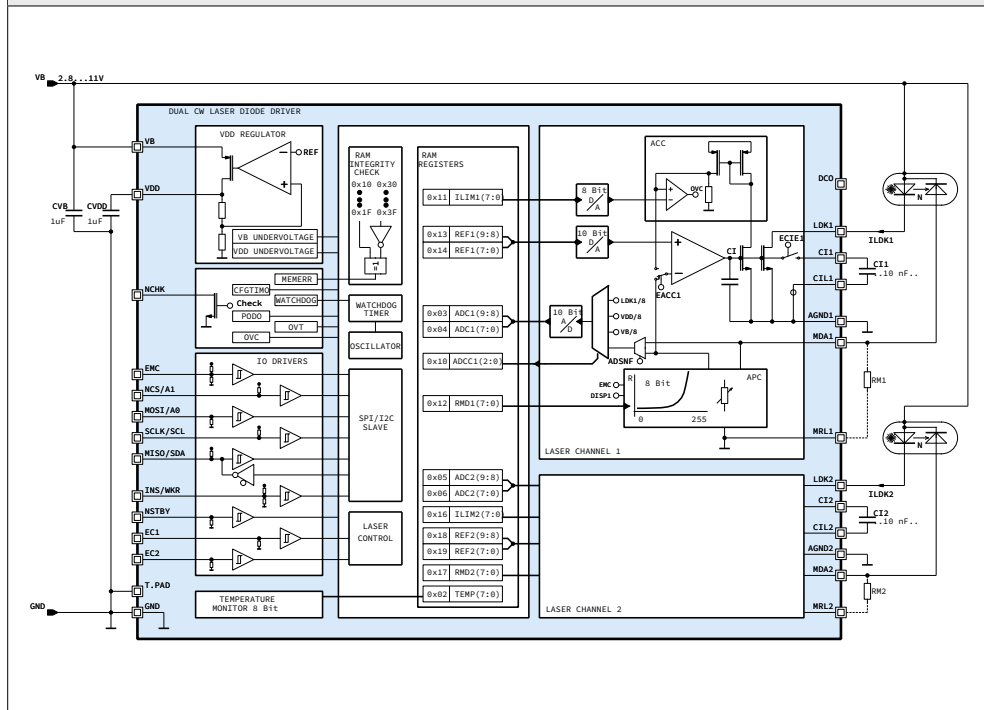

Copyright © 2013, 2022 iC-Haus

iC-HT

DUAL CW LASER DIODE DRIVER

Rev C1, Page 2/46

DESCRIPTION

Dual CW laser diode driver iC-HT can operate two individual laser diodes with up to 750 mA laser current depending on the heat dissipation. Each channel can be enabled independently. The laser diode driver can be controlled by an external microcontroller (MCU mode) or operate stand alone with pin/resistor configuration (iC-WK mode). In MCU mode, both channels can be combined for driving up to 1500 mA.

Each channel can be operated individually either in automatic current control (ACC) or automatic power control (APC). All parameters including the internal reference voltages are set via serial communication (I²C or SPI). A 10 bit resolution D/A converter with logarithmic characteristic is used for setting the operating point. This allows an operating point resolution better than 1%.

In APC control, the monitor diode photocurrent is used to track the optically emitted power of the laser diode. The feedback for the laser diode driver is the voltage of the photocurrent at a monitor resistor. An 8 bit internal programmable logarithmic monitor resistor (PLR) or an external monitor resistor can be selected for closing the control loop. The PLR ranges from 100 Ω to 500 kΩ with a step width less than 5%.

In ACC control, the laser diode current can be set directly. Two current ranges are selectable.

iC-HT allows disabling the laser channels when an overcurrent threshold has been exceeded. The over-

current threshold of each channel has 2 ranges and is programmable through an 8 bit linear D/A converter.

The temperature monitor measures the internal chip temperature. iC-HT disables the laser channels when overtemperature is detected.

A variety of voltages can be measured with a 10 bit A/D converter. The following voltages can be measured:

- V(LDKx)
- V(VDD)
- V(VB)
- V(MDAx)
- V(PLRx)

The DCO current output pin can control an external DC/DC converter. Controlling the DC/DC output voltage can optimize the power dissipation of the whole system e.g. to extend battery life.

iC-HT in standby mode has a very low current consumption (< 10 μA) and does retain its configuration.

The device features for **safe operation**:

- Configuration verification
- Tri-state configuration pins
- Write protection in operating mode
- Safe default/startup state

iC-HT DUAL CW LASER DIODE DRIVER

Rev C1, Page 3/46

PACKAGING INFORMATION QFN28 5 mm x 5 mm to JEDEC

PIN CONFIGURATION QFN28 5 mm x 5 mm (topview)

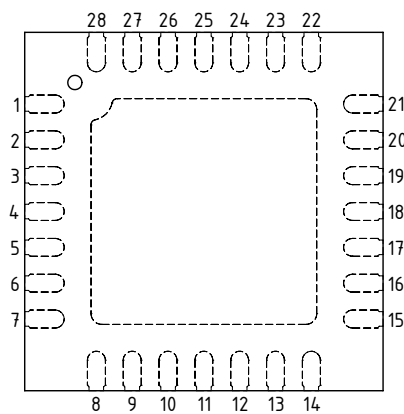

PIN FUNCTIONS

No.	Name	Function
1	LDK1	Laser Diode Cathode for channel 1
2	LDK1	Laser Diode Cathode for channel 1
3	AGND1	Analog Ground for channel 1
4	CI1	Integration Capacitor for channel 1
5	CIL1	Integration Capacitor for channel 1, low side
6	MDA1	Monitor Diode Anode for channel 1
7	MRL1	Monitor Resistor for channel 1, low side
8	EMC	Enable Microcontroller input
9	SCLK/SCL	SPI Clock / I ² C Clock
10	MISO/SDA	SPI Master In Slave OUT / I ² C Data
11	MOSI/A0	SPI Master Out Slave In / I ² C Address Bit 0
12	NCS/A1	Chip Select, active low / I ² C Address bit 1
13	EC1	Enable Channel 1 input
14	EC2	Enable Channel 2 input
15	MRL2	Monitor Resistor for channel 2, low side
16	MDA2	Monitor Diode Anode for channel 2
17	CIL2	Integration Capacitor for channel 2, low side
18	CI2	Integration Capacitor for channel 2
19	AGND2	Analog Ground for channel 2
20	LDK2	Laser Diode Cathode for channel 2
21	LDK2	Laser Diode Cathode for channel 2
22	GND	Ground
23	DCO	Digital Current Output
24	INS/WKR	I ² C or SPI selection input / Reference voltage selection in iC-WK mode
25	VDD	3.3V output supply
26	VB	Power supply
27	NCHK	Error output, active low
28	NSTBY	Standby input, active low
TP		Thermal Pad (GND)

The *Thermal Pad* is to be connected to a *Ground Plane* (GND, AGND1...2) on the PCB.

Only pin 1 marking on top or bottom defines the package orientation (@ HT label and coding is subject to change).

iC-HT DUAL CW LASER DIODE DRIVER

Rev C1, Page 4/46

PACKAGE DIMENSIONS QFN28-5x5

All dimensions given in mm.
This package falls within JEDEC MO-220-VHHD-1.

RECOMMENDED PCB-FOOTPRINT

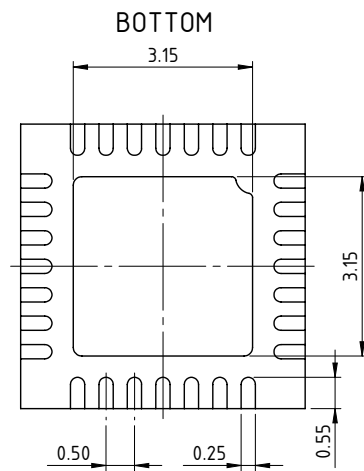
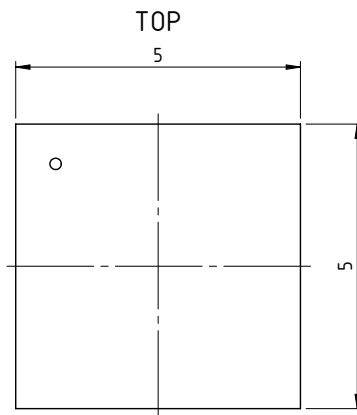
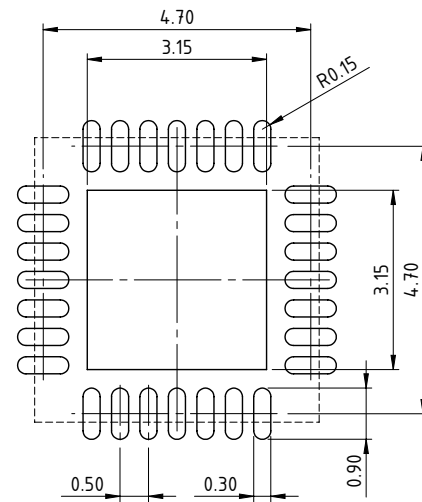
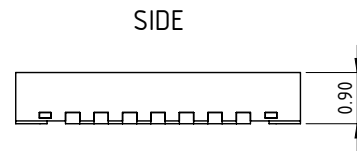

drb_qfn28-2_pack_1_10:1

iC-HT DUAL CW LASER DIODE DRIVER

Rev C1, Page 5/46

ABSOLUTE MAXIMUM RATINGS

These ratings do not imply permissible operating conditions; functional operation is not guaranteed. Exceeding these ratings may damage the device.

Item No.	Symbol	Parameter	Conditions			Unit
				Min.	Max.	
G001	VB	Voltage at VB		-0.3	11	V
G002	I(VB)	Current in VB		-20	50	mA
G003	VDD	Voltage at VDD		-0.3	5.5	V
G004	I(VDD)	Current in VDD		-20	1	mA
G005	V()	Voltage at C11, C12, EC1, EC2, MDA1, MDA2, EMC, SCLK/SCL, MISO/SDA, MOSI/A0, NCS/A1, DCO, INS/WKR, NCHK		-0.3	5.5	V
G006	I()	Current in C11, C12, EC1, EC2, MDA1, MDA2, EMC, SCLK/SCL, MISO/SDA, MOSI/A0, NCS/A1, DCO, INS/WKR, NCHK, NSTBY, CIL1, CIL2, MRL1, MRL2		-20	20	mA
G007	I(LDK)	Current in LDK1, LDK2	DC current	-20	900	mA
G008	V()	Voltage at LDK1, LDK2, NSTBY		-0.3	11	V
G009	V()	Voltage at AGND1, AGND2		-0.3	1	V
G010	I(AGND)	Current in AGND1, AGND2	DC current	-900	1	mA
G011	Vd()	ESD Susceptibility at all pins	HBM 100 pF discharged through 1.5kΩ		2	kV
G012	Tj	Operating Junction Temperature		-40	125	°C
G013	Ts	Storage Temperature Range		-40	150	°C

THERMAL DATA

Operating Conditions: VB = 2.8 ... 11 V (referenced to GND)

Item No.	Symbol	Parameter	Conditions				Unit
				Min.	Typ.	Max.	
T01	Ta	Operating Ambient Temperature Range		-40		85	°C
T02	Rthja	Thermal Resistance Chip/Ambient	Mounted on PCB		25		K/W
T03	RthjTP	Thermal Resistance Chip/Thermal Pad			4		K/W

All voltages are referenced to ground unless otherwise stated.
All currents flowing into the device pins are positive; all currents flowing out of the device pins are negative.

iC-HT DUAL CW LASER DIODE DRIVER

Rev C1, Page 6/46

ELECTRICAL CHARACTERISTICS

Operating Conditions: VB = 2.8 ... 11 V (referenced to GND), Tj = -40 ... 125 °C unless otherwise stated

Item No.	Symbol	Parameter	Conditions	Min.	Typ.	Max.	Unit
Total Device							
Functionality and parameters beyond the operating conditions (with reference to independent voltage supplies, for instance) are to be verified within the individual application using FMEA methods.							
001	VB	Permissible Supply Voltage	Referenced to GND	2.8		11	V
002	I(VB)	Standby Current at VB	$V(NSTBY) \leq 0.4 V$			10	μA
003	I(VB)	Supply Current at VB	No load, EC1, EC2, NSTBY = hi			5	mA
004	V(VB)on	Turn-on threshold	Increasing VB	1.6		2.7	V
005	V(VB)off	Turn-off threshold	Decreasing VB	1.45		2.6	V
006	V(VB)Hys	Power-on hysteresis		20		250	mV
007	V(VDD)on	Turn-on threshold	Increasing VDD	1.6		2.4	V
008	V(VDD)off	Turn-off threshold	Decreasing VDD	1.45		2.3	V
009	V(VDD)Hys	Power-on hysteresis		20		250	mV
010	V(VB)INITR	RAM memory reset during Stand-By	NSTBY = lo	0.85		1.4	V
011	Rgnd()	Resistor to GND at MRL1, MRL2				20	Ω
012	Ragnd()	Resistor to AGNDx at CILx				20	Ω
013	Vc()lo	Clamp Voltage lo at VB, VDD, NCHK, EMC, NCS/A1, MISO/SDA, MOSI/A0, SCLK/SCL, INS/WKR, NSTBY, EC1, EC2, DCO, LDK1, LDK2, CI1, CIL1, CI2, CIL2, AGND1, AGND2, MDA1, MDA2	I() = -10 mA	-1.6		-0.3	V
Laser Driver LDKx, Clx, MDAx							
101	Vs(LDK)lo	Saturation Voltage lo at LDK	I(LDKx) = 750 mA			0.7	V
102	V(LDKSAT)	LDKx saturation detection threshold	RLDKSx = 00 RLDKSx = 01 RLDKSx = 10 RLDKSx = 11	0.35 0.55 0.85 1.05	0.5 0.7 1 1.2	0.65 0.85 1.15 1.35	V
103	Idc(LDK)	Permissible DC Current at LDKx				750	mA
104	Ileak(LDK)	LDKx leakage current	V(LDKx) = 11 V			10	μA
105	C(CI)	Possible capacitor at CI1, CI2	ECIE = 0, EMC = hi	0			μF
106	I(CI)	Charge Current at CI1, CI2	V(CI) = 0 V, EC1, EC2 = hi, ECIE = 1 COMP = 111	-220		-30	μA
107	I(LDK)max	Laser overcurrent shutdown threshold	V(LDKx) = 0.7 V ... VB - 1.5 V ILIMx(7:0) = 0x00, RACCx = 0 ILIMx(7:0) = 0xFF, RACCx = 0 ILIMx(7:0) = 0x00, RACCx = 1 ILIMx(7:0) = 0xFF, RACCx = 1	0 750 0 80		25 1400 3.2 175	mA mA mA mA
108	$\Delta I(LDK)$	Shutdown threshold resolution	RACCx = 0 RACCx = 1	2.8 0.3	4 0.5	5.2 0.8	mA mA
109	tovc	Time to overcurrent shutdown	Laser current decreased 10%	1		5	μs
110	V(MDA)	Voltage at MDA1, MDA2	Closed control loop EC1, EC2 = hi EMC = lo, INS/WKR = lo EMC = lo, INS/WKR = hi	225 455	250 500	275 545	mV mV
111	Ten	Time to laser enabled	NSTBY lo \rightarrow hi, no load at VDD, V(VDD) 0 to 90%, CVDD = 1 μF , EMC = lo			1.3	ms
112	Tci	Time to light	NSTBY = hi, ECIE = 0, COMP = 010, light off to 80% target value			300	μs
113	Tcio	Time to target light	Light from 80% to 99% target value			4700	μs

iC-HT DUAL CW LASER DIODE DRIVER

Rev C1, Page 7/46

ELECTRICAL CHARACTERISTICS

Operating Conditions: VB = 2.8 ... 11 V (referenced to GND), Tj = -40 ... 125 °C unless otherwise stated

Item No.	Symbol	Parameter	Conditions	Min.	Typ.	Max.	Unit
114	I _{dc(LDK)}	LDKx ACC mode current	EC1, EC2, EMC = hi, EACCx = 1, V(LDKx) = 0.7 V ... VB - 1.5 V REFx(9:0) = 0x000, RACCx = 0 REFx(9:0) = 0x3FF, RACCx = 0 REFx(9:0) = 0x000, RACCx = 1 REFx(9:0) = 0x3FF, RACCx = 1	50 650 5 70	82 750 10 113	120 1400 15 160	mA mA mA mA
115	Tk	Temperature coefficient ACC mode		-1500	-500	0	ppm/K
Programmable Resistor							
201	R _{mda}	Resistor at MDAX pin	RMDx(7:0) = 0xF0 ... 0xFF, DISPx = 0 RMDx(7:0) = 0x00 ... 0x0F, DISPx = 0	350 0.154	500 0.220	650 0.286	kΩ kΩ
202	Tk	Temperature coefficient		-1500	-500	0	ppm/K
203	ΔR	Resistor increment	$\Delta R = \frac{R(n+1) - R(n)}{R(n)}$	2	3.3	5	%
204	I _{leak(MDA)}	MDAX leakage current	DISPx = 1	-1		1	μA
D/A Converter							
301	R(DAC)	D/A Converter Resolution				10	bit
302	ΔV	Percentual voltage increments	$\Delta V = \frac{V(n+1) - V(n)}{V(n)}$	0.1	0.235	0.5	%
303	V(DAC)	D/A Converter	REFx(9:0) = 0x000 lowest value REFx(9:0) = 0x3FF highest value	0.09 1.00	0.10 1.10	0.12 1.25	V V
Check Output NCHK							
401	V _{s(lo)}	Saturation Voltage I _o at NCHK	I(NCHK) = 1.0 mA			0.4	V
402	I _{sc(lo)}	Short Circuit Current I _o at NCHK	V(NCHK) = 0.4 ... 3.3 V	9		33	mA
403	I _{lk()}	Leakage Current at NCHK	NCHK = 1; V(NCHK) = 0 ... 5.5 V	-1		1	μA
Series Regulator Output VDD							
501	V(VDD)	Regulated output voltage	VB = 3.7 ... 8 V, I(VDD) = -10 ... 0 mA NSTBY = hi	3		3.5	V
502	V(VB,VDD)	Voltage Drop between VB and VDD	VDD unregulated, I(VDD) = -10 ... 0 mA NSTBY = hi		100	400	mV
503	C(VOUT)	Capacitor at VDD	Ri(C) < 1 Ω	1		3.3	μF
504	T _{vdd}	Settling time VDD	NSTBY lo → hi, no load at VDD, V(VDD) 0 to 90 % CVDD = 1 μF			1	ms
Digital inputs							
601	Vt(jhi)	Input Threshold Voltage hi at NCS/A1, MISO/SDA, MOSI/A0, SCLK/SCL, NSTBY, EC1, EC2				2	V
602	Vt(jlo)	Input Threshold Voltage lo at NCS/A1, MISO/SDA, MOSI/A0, SCLK/SCL, NSTBY, EC1, EC2	VB > 3 V VB = 2.8 V	0.7 0.6			V V
603	Vt(jhys)	Hysteresis at NCS/A1, MISO/SDA, MOSI/A0, SCLK/SCL, NSTBY, EC1, EC2	Vt(jhys) = Vt(jhi) - Vt(jlo)	100			mV
604	I _{pd()}	Pull-Down Current at MOSI/A0, EC1, EC2	V() = 0.4 V ... VDD	1		50	μA
605	I _{pd()}	Pull-Down Current at NSTBY	V() = 0.4 V ... VB	1		50	μA
606	R _{pu()}	Pull-Up Resistor at SCLK/SCL, NCS/A1		80	150	260	kΩ
607	R _{pu()}	Pull-Up Resistor at MISO/SDA	EMC = hi, INS/WKR = lo EMC = hi, INS/WKR = hi	8 53	20 100	50 174	kΩ kΩ
608	Er()	Safe enable threshold voltage at EMC, INS/WKR	Rising Falling	52 30	54 32	56 34	% VDD % VDD
609	Voc()	Open Circuit Voltage at EMC, INS/WKR		39	41	43	% VDD
610	Ri()	Internal Resistance at EMC, INS/WKR		170	250	330	kΩ

iC-HT DUAL CW LASER DIODE DRIVER

Rev C1, Page 8/46

ELECTRICAL CHARACTERISTICS

Operating Conditions: $V_B = 2.8 \dots 11 \text{ V}$ (referenced to GND), $T_j = -40 \dots 125 \text{ }^\circ\text{C}$ unless otherwise stated

Item No.	Symbol	Parameter	Conditions	Min.	Typ.	Max.	Unit
611	Isc(I)lo	Short Circuit current I _o at MISO/SDA	INS/WKR = I _o , V(MISO/SDA) = 5.5 V	-40		-4	mA
612	Vs(I)lo	Saturation Voltage I _o at MISO/SDA	INS/WKR = I _o , I(MISO/SDA) = 2 mA			0.4	V
A/D Converter							
701	Ton	Converter initialization time	ADCCx(2) changes from 0 to 1, LDKx, VDD or V _B measurements			500	µs
702	Tconv	Conversion time				140	µs
703	R(ADC)	A/D Converter Resolution				10	bit
704	RAC	Relative Accuracy		-1		+1	LSB
705	VZS()	Zero Scale Voltage	ADCx(9:0) = 000h		0		V
706	VFS()	Full Scale Voltage	ADCx(9:0) = 3FFh	1.0	1.1	1.2	V
707	MDAM	MDAx Measurement	MDAx = 0.5 V, ADCCx(2:0) = 100, ADSNFx = 0	372	465	558	LSB
708	VDDM	VDD Measurement	VDD = 3.3 V, ADCCx(2:0) = 110	312	390	468	LSB
709	VBM	V _B Measurement	V _B = 8 V, ADCCx(2:0) = 101	744	930	1023	LSB
710	LDKM	LDKx Measurement	LDKx = 8 V, ADCCx(2:0) = 111	744	930	1023	LSB
Overtemperature							
B01	Toff	Overtemperature Shutdown	Rising temperature	130		170	°C
B02	Ton	Overtemperature Release	Falling temperature	120		165	°C
B03	Thys	Hysteresis	Toff – Ton	3			°C
Temperature Monitor							
C01	Trange	Temperature Measurement Range		-40		125	°C
C02	Tresol	Temperature Measurement Resolution			1		°C
C03	Reading	Temperature Value Ranges	T _j = 125 °C T _j = -40 °C	160 0		190 15	digits digits
DCO Output							
D01	Isc(j)hi	DCO Output Current	V(VDD) = 3...3.5 V, V(DCO) < 1.4 V, RDCO = 0x3F	-175	-130	-85	µA
D02	Ileak	Leakage Current at DCO	RDCO = 0x00 or NSTBY = I _o , V(DCO) = 0 ... 5.5 V	-1		1	µA
D03	I(DCO)LSB	I(DCO) Resolution	V(DCO) < 1.4 V	1.3	2	2.7	µA
Oscillator							
E01	Fosc	Oscillator Frequency	NSTBY = hi	100	200	400	kHz
E02	T(cfgtmo)	Configuration Mode Timeout	MODE(1:0) = 10	40	82	164	ms
E03	tWDT	Watchdog Timeout	NSTBY = hi	20		120	µs

OPERATING REQUIREMENTS: SPI and I²C Interface

Operating Conditions: $V_B = 2.8 \dots 11 \text{ V}$, $T_j = -40 \dots 125 \text{ }^\circ\text{C}$

Item No.	Symbol	Parameter	Conditions	Min.	Max.	Unit
SPI / I²C Interface Timing						
I001	tsCCL	Setup Time: NCS/A1 hi → I _o before SCLK I _o → hi	INS/WKR = I _o	20		ns
I002	tsDCL	Setup Time: MOSI/A0 stable before SCLK/SCL I _o → hi	INS/WKR = I _o	20		ns

iC-HT DUAL CW LASER DIODE DRIVER

Rev C1, Page 9/46

OPERATING REQUIREMENTS: SPI and I²C Interface

Operating Conditions: VB = 2.8 ... 11 V, Tj = -40 ... 125 °C

Item No.	Symbol	Parameter	Conditions	Min. / Max.		Unit
				Min.	Max.	
I003	thDCL	Hold Time: MOSI/A0 stable after SCLK/SCL lo → hi	INS/WKR = lo	20		ns
I004	tCLh	Signal Duration SCLK/SCL hi	INS/WKR = lo	50		ns
I005	tCLI	Signal Duration SCLK/SCL lo	INS/WKR = lo	50		ns
I006	thCLC	Hold Time: NCS/A1 lo after SCLK/SCL hi → lo	INS/WKR = lo	20		ns
I007	tCSh	Signal Duration NCS/A1 hi	INS/WKR = lo	50		ns
I008	tpCLD	Propagation Delay: MISO/SDA stable after SCLK/SCL hi → lo	INS/WKR = lo, V(VDD) > 3 V, Cload = 10 pF, no external pull-up	0	30	ns
I009	tHIZ	MISO to HIZ delay	INS/WKR = lo	0	25	ns
I010	f(SCLK)	SPI clock frequency			10	MHz
I011	f(SCL)	I ² C clock frequency			400	kHz

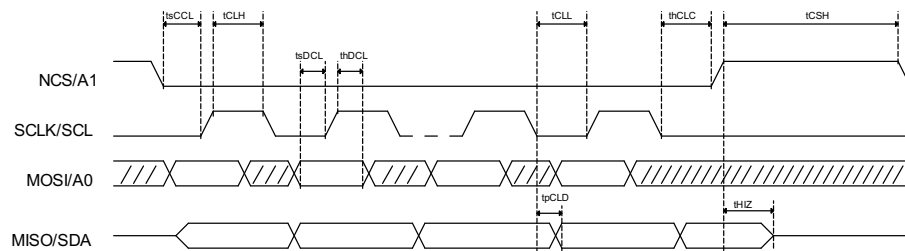

Figure 1: SPI interface timing

iC-HT

DUAL CW LASER DIODE DRIVER

Rev C1, Page 10/46

OPERATING AND STANDBY MODES

iC-HT operating modes are selected by the pins EMC and INS. These pins are intended to be static and should not be changed during operation to avoid mis-configuration or unintended operation. It is recommended to tie the pins EMC and INS to VDD or GND. Floating pins EMC and INS/WKR are detected as faulty configuration and signaled at NCHK.

iC-WK mode

In iC-WK mode the iC-HT operates as an Automatic Power Control (APC) laser controller, similar to iC-Haus' [iC-WK/iC-WKL](#), [iC-WKM](#) and [iC-WKN](#). iC-WK mode is set by pin configuration and the external monitor resistor. Pin EMC is set to lo and pin INS/WKR selects the reference voltage:

- INS/WKR = hi for 0.5 V reference voltage, similar to iC-WK, iC-WKL, iC-WKN.
- INS/WKR = lo for 0.25 V reference voltage, similar to iC-WM.

Floating pins EMC and INS/WKR are detected as faulty configuration and signaled at NCHK.

MCU mode

In microcontroller unit (MCU) mode, iC-HT features two control modes: automatic power control (APC) and automatic current control (ACC). Pin EMC is set to hi and pin INS/WKR selects the serial communication interface protocol. Selection of the communication protocol is achieved through pin INS/WKR:

- INS/WKR = hi for I2C.
- INS/WKR = lo for SPI.

Floating pins EMC and INS/WKR are detected as faulty configuration and signaled at pin NCHK. Any input interface could be enabled if EMC or INS pins are open. Communication with the chip might be possible but laser cannot be switched on. This situation is only signaled at pin NCHK, which would remain low as long as any of the EMC or INS pins are unconnected. MCU must monitor the status of the pin NCHK to get all the status information of the chip.

Standby mode

iC-HT in standby mode has a very low current consumption ($< 10 \mu\text{A}$) and does retain its configuration. Standby mode will not reset the internal RAM.

In order to exit standby mode, pin NSTBY must be set to hi (e.g. VB). VDD is switched off in standby mode and can not be used to exit standby mode.

VB, NSTBY and LDKx withstand voltages up to 11 V, whereas the remaining input pins operate up to 5.5 V and do have high impedance at standby mode.

Information on timing after waking up from standby mode can be found on page 36.

iC-HT DUAL CW LASER DIODE DRIVER

Rev C1, Page 11/46

LASER DIODE/LED TYPES AND OPERATION MODES

For APC operation a monitor diode is required. This operation is possible in microcontroller unit (MCU) mode and in the iC-WK mode.

In automatic current control (ACC) operation there is no monitor diode and any diode can be operated in microcontroller unit (MCU) mode.

iC-HT can operate in APC two types of laser diodes/LEDs with monitor diodes:

- N-type laser diodes
- M-type laser diodes

All operations are possible with laser diodes (LDs) or light emitting diodes (LEDs). In the following text we do not differ between laser diodes (LDs) and light emitting diodes (LEDs).

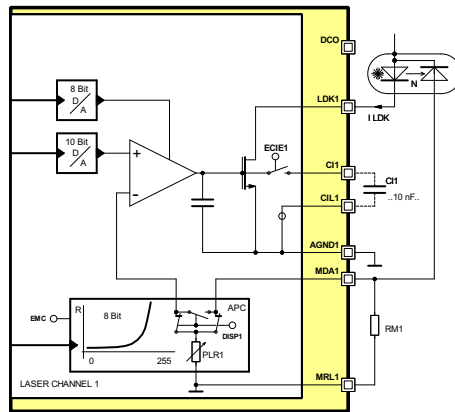

Figure 2: iC-HT with N-type laser diode

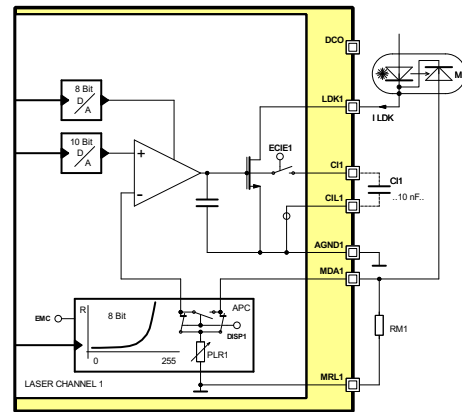

Figure 3: iC-HT with M-type laser diode

iC-HT DUAL CW LASER DIODE DRIVER

Rev C1, Page 12/46

iC-WK MODE

Setting pin EMC = Io configures iC-HT for iC-WK mode. EMC pin must be set to GND.

In iC-WK mode both channels operate in APC mode. The internal programmable logarithmic monitor resistors are disabled, therefore connection of external resistors at pins MDAX is required.

The APC reference can be set to two different values by means of pin INS/WKR, as explained in table 1, and the overcurrent threshold is set to its maximum value of 750 mA (cf. *Electrical Characteristics No. 107*). In case of overcurrent, the respective channel is disabled. For re-enabling the channel, the corresponding ECx pin must be cycled.

Reference Voltage in iC-WK mode		
INS/WKR	Reference Voltage	similar to
Lo	0.25 V	iC-WKM
Hi	0.5 V	iC-WK, iC-WKL, iC-WKN

Table 1: Reference selection (cf. *Electrical Characteristics No. 110*)

External CI capacitors must be added in this operation mode at pins Clx and ClLx. Figure 4 shows an example in iC-WK mode using an N-type laser diode, where 0.5 V reference is selected. Figure 5 presents the same configuration with an M-type laser diode.

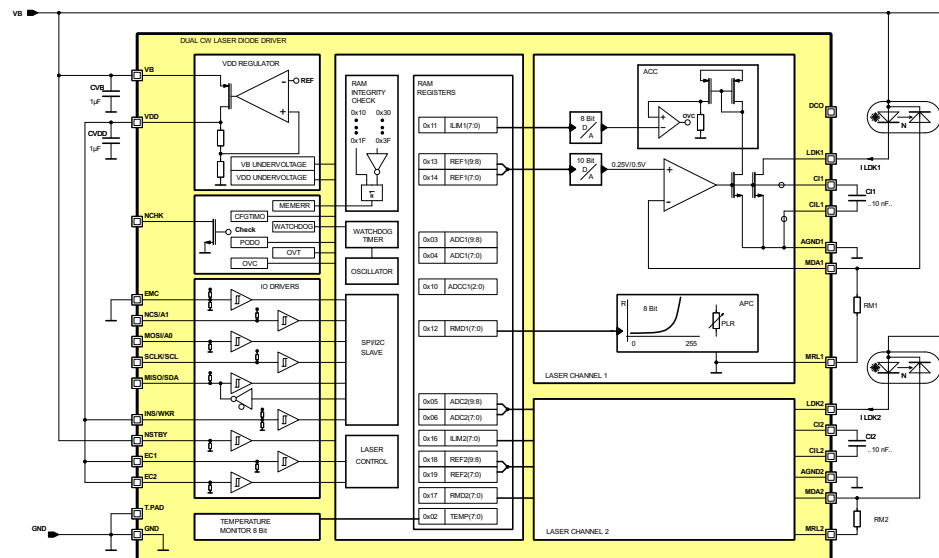

Figure 4: iC-HT in iC-WK mode with N-type laser diode

iC-HT
DUAL CW LASER DIODE DRIVER

Rev C1, Page 13/46

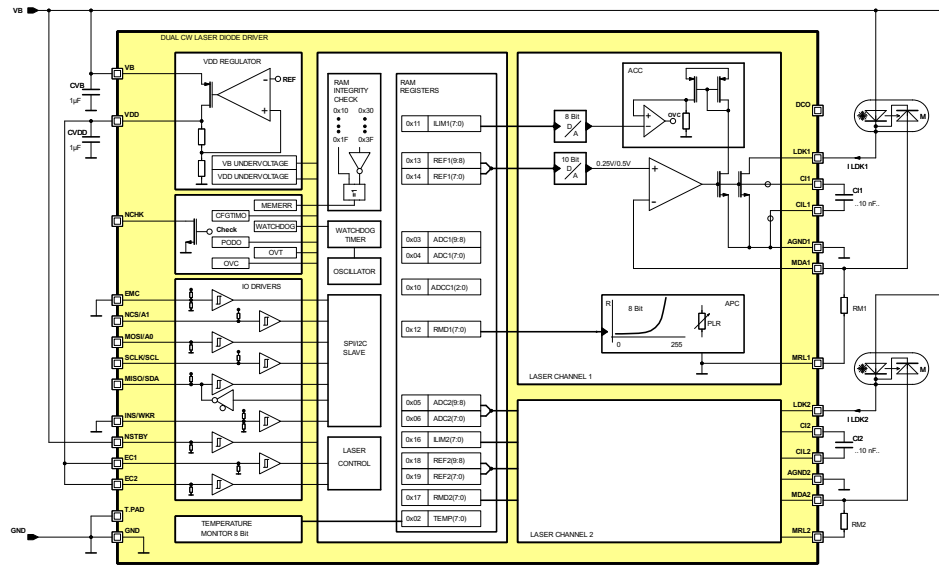

Figure 5: iC-HT in iC-WK mode with M-type laser diode

In the configuration as per Figures 4 and 5 pin, NSTBY is connected to VB. This is required to force iC-HT leaving standby mode and starting normal operation, as the pin includes an internal pull-down resistor.

Laser channel enabling

Setting pins EC1, EC2 to hi enables the corresponding channels. In order to ensure safe operation of iC-HT, several events automatically disable both output channels:

- Pins INS/WKR or EMC left unconnected (INSOPEN, EMCOPEN), iC-HT enters error mode and the laser channels cannot be enabled.

- Supply power-down either at VB (PDoVB) or VDD (PDoVDD), the laser channels are unconditionally disabled during the power down event.

- Overcurrent (OVC) or overtemperature (OVT), laser channels are switched off. Cycling pins EC1, EC2 or a power-up is required to switch on the laser again.

These events are signalled with a low level at pin NCHK (see Fig. 6)

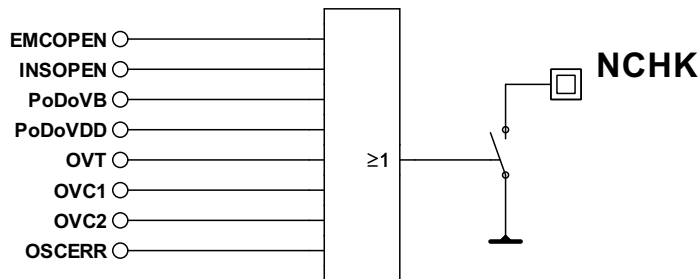

Figure 6: iC-HT in iC-WK mode, NCHK function

iC-HT DUAL CW LASER DIODE DRIVER

Rev C1, Page 14/46

MICROCONTROLLER MODE

Setting pin EMC to hi configures iC-HT for microcontroller mode (MCU mode). Pin EMC must be set using a pull-up resistor or directly short-circuited to pin VDD. Several parameters can be configured through a microcontroller via I²C or SPI communication. See page 24.

The configuration of the internal parameters of iC-HT must be done in configuration mode. In this mode, the configuration memory can be written and read back without changing the previous configuration state of iC-HT. Once the configuration is considered as valid, iC-HT can be switched to operation mode. These two modes are configured by the MODE register. If the time in configuration mode exceeds the Configuration Mode Timeout (cf. *Electrical Characteristics No. E02*), both channels will be switched off. See page 34.

Each individual channel can be enabled by setting pin EC_x to hi. Setting register bits DISC_x to 1 disables the corresponding channel. If either pin EC_x is lo or register bits DISC_x is 1, the corresponding channel is disabled.

DISC1		Addr. 0x10; bit 3	R/W 1
Code	Function		
0	Channel 1 can be enabled by pin EC1		
1	Channel 1 cannot be enabled by pin EC1		

Table 2: Disable channel 1

DISC2		Addr. 0x15; bit 3	R/W 1
Code	Function		
0	Channel 2 can be enabled by pin EC2		
1	Channel 2 cannot be enabled by pin EC2		

Table 3: Disable channel 2

Different voltages can be measured using a 10 bit A/D converter with two resolutions. The following internal voltages can be measured:

- V(LDK_x) up to 8 V with 8.6 mV resolution
- V(VDD) up to 8 V with 8.6 mV resolution
- V(VB) up to 8 V with 8.6 mV resolution
- V(MDA_x) up to 1 V with 1.075 mV resolution
- V(PLR_x) up to 1 V with 1.075 mV resolution

The register bits ADCC_x select the signal measured with the 10 bit A/D converter.

ADCC1(2:0)		Addr. 0x10; bit 7:5	R/W 000
Code	Function		
0xx	Disabled		
100	V(MDA1), ADSNF1 = 0		
100	V(PLR1), ADSNF1 = 1		
101	V(VB)		
110	V(VDD)		
111	V(LDK1)		

Table 4: ADC channel 1 source selection

ADCC2(2:0)		Addr. 0x15; bit 7:5	R/W 000
Code	Function		
0xx	Disabled		
100	V(MDA2), ADSNF2 = 0		
100	V(PLR2), ADSNF2 = 1		
101	V(VB)		
110	V(VDD)		
111	V(LDK2)		

Table 5: ADC channel 2 source selection

With ADCC_x(2:0) = 100, the signal to the A/D converter is selected by register bit ADSNF_x. With ADSNF_x = 1 the measuring point to the A/D converter is the internal sense node of the internal programmable logarithmic monitor resistor (PLR). With ADSNF_x = 0 the sensing point is connected directly to MDA_x pin.

ADSNF1		Addr. 0x1A; bit 2	R/W 0
Code	Function		
0	ADC measurement pin MDA1 (force)		
1	ADC measurement PLR1 (sense)		

Table 6: ADC channel 1 sense/force selection

ADSNF2		Addr. 0x1A; bit 6	R/W 0
Code	Function		
0	ADC measurement pin MDA2 (force)		
1	ADC measurement PLR2 (sense)		

Table 7: ADC channel 2 sense/force selection

iC-HT
DUAL CW LASER DIODE DRIVER

Rev C1, Page 15/46

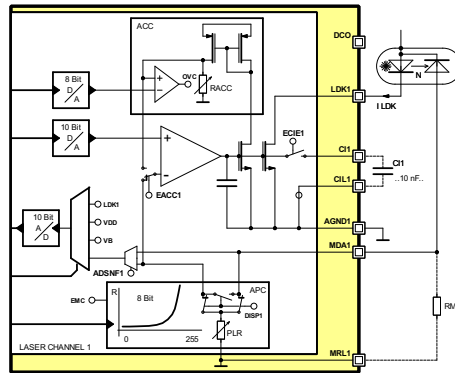

Figure 7: Channel 1 schematic

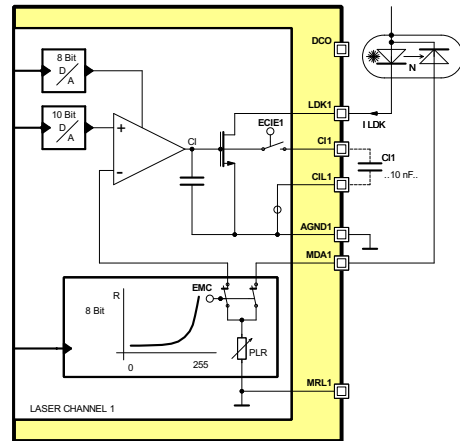

Figure 8: APC mode simplified

Two different control modes can be configured independently for each channel: automatic power control (APC) and automatic current control (ACC). In both modes a 10 bit logarithmic D/A converter sets the reference voltage and an 8 bit programmable D/A converter configures the overcurrent threshold.

APC (Automatic Power Control) mode

In APC mode the laser power is controlled. The monitor diode current is used as feedback in the laser power control loop. APC mode is selected by setting EACCx register bit to 0.

EACC1		Addr. 0x10; bit 0	R/W 0
Code	Function		
0	APC mode enabled for channel 1		
1	ACC mode enabled for channel 1		

Table 8: APC/ACC in channel 1

EACC2		Addr. 0x15; bit 0	R/W 0
Code	Function		
0	APC mode enabled for channel 2		
1	ACC mode enabled for channel 2		

Table 9: APC/ACC in channel 2

An example of APC with default configuration is shown in Figure 8.

An internal 8 bit programmable logarithmic monitor resistor (PLR) can be used in APC mode. In APC mode it is also possible to use an external monitor resistor connected to pin MDAX. If register bit DISPx is 0, the PLR is present. If DISPx is 1, the PLR is disabled and an external monitor resistor must be used.

DISP1		Addr. 0x10; bit 2	R/W 0
Code	Function		
0	PLR enabled for channel 1		
1	PLR disabled for channel 1		

Table 10: Disable PLR channel 1

DISP2		Addr. 0x15; bit 2	R/W 0
Code	Function		
0	PLR enabled for channel 2		
1	PLR disabled for channel 2		

Table 11: Disable PLR channel 2

Both programmable logarithmic monitor resistors (PLR) feature a wide logarithmic resistor range from 100 Ω to 500 kΩ, in steps of typically 3.3%. This covers a wide range of monitor currents. More information about the PLR can be found on page 26.

For fine-tuning the optical power, the reference voltage can be set with a 10 bit logarithmic D/A converter, which is configurable through the register REFx. This converter has a voltage range that goes typically from 0.1 V to 1.1 V, allowing an operation resolution of typically 0.235%. See page 27.

iC-HT DUAL CW LASER DIODE DRIVER

Rev C1, Page 16/46

For calculating the minimum value of I_{mon} , $V_{ref}(0x00$, max. value) (cf. *Electrical Characteristics No. 303*) and $R_{mda}(RMDx = 0xFF$, min. value) (cf. *Electrical Characteristics No. 201*) are used.

$$I_{mon(min)} = \frac{V_{ref}(0x00, max)}{R_{mda}(RMDx=0xFF, min)} = \frac{0.11}{350000} = 0.31 \mu A$$

It is not recommended to configure iC-HT to have such small I_{mon} values, otherwise the leakage current at $MDAx$ may have an influence (cf. *Electrical Characteristics No. 204*), especially at high temperatures. To avoid this, I_{mon} should be much greater than the leakage current.

For calculating the maximum value of I_{mon} , $V_{ref}(0x3FF$, min. value) (cf. *Electrical Characteristics No. 303*) and $R_{mda}(RMDx = 0x00$, max. value) (cf. *Electrical Characteristics No. 201*) are used. The following formula can be used for calculating $R_{mda}(RMDx = 0x00$, max. value):

$$R_{md} = R_{md_0} \left(1 + \frac{\Delta R_{md}(\%)}{100}\right)^{n+1}, n \text{ from } 0 \text{ to } 255$$

$$R_{mda}(RMDx = 0x00, max) = R_{md_0} \left(1 + \frac{\Delta R_{md}(\%)}{100}\right)^{16}$$

$$286 = R_{md_0} \left(1 + \frac{3.3}{100}\right)^{16}$$

$$R_{md_0} = 170 \Omega$$

Therefore:

$$I_{mon(max)} = \frac{V_{ref}(0x3FF, min)}{R_{md_0}} = \frac{1.00}{170} = 5.88 \text{ mA}$$

Any other I_{mon} value can be calculated using R_{md} formula above. Due to its logarithmic characteristic, the steps between two consecutive values is kept within 3.3 % typical value.

The programmable overcurrent shutdown can be set to protect the laser by disabling the channel. The overcurrent threshold is configurable in two different ranges. The range is selected through register bit $RACCx$. If $RACCx = 1$, the overcurrent threshold is in the low range, up to 90 mA. If $RACCx = 0$, the overcurrent threshold is in the high range, up to 750 mA (cf. *Electrical Characteristics No. 107*).

RACC1		Addr. 0x1A; bit 0	R/W 0
Code	Function		
0	Current range high for channel 1		
1	Current range low for channel 1		

Table 12: RACC1 current range configuration channel 1

RACC2		Addr. 0x1A; bit 4	R/W 0
Code	Function		
0	Current range high for channel 2		
1	Current range low for channel 2		

Table 13: RACC2 current range configuration channel 2

In each range, the particular overcurrent threshold value can be set in register $ILIMx$. The regulator does not differ the two current ranges in APC.

Note: The accuracy of the overcurrent detection depends on the correct biasing of the driver stage. If the driver is saturated, the accuracy of the overcurrent detection is reduced and may not work as expected. Saturation voltage (*Electrical Characteristics No. 101*) must be ensured for a proper function of the overcurrent detection. $LDKSAT1$ and $LDKSAT2$ status bits can be used for anticipated saturation detection.

ILIM1		Addr. 0x11; bit 7:0	R/W 0xFF
Code	Function		
0x0A	Channel 1 overcurrent threshold set to minimum current		
...	Channel 1 overcurrent threshold set to $I_{lim} = (\Delta I(LDK) \cdot n)$, n from 10 to 255		
0xFF	Channel 1 overcurrent threshold set to maximum current		

Table 14: Overcurrent threshold configuration channel 1

ILIM2		Addr. 0x16; bit 7:0	R/W 0xFF
Code	Function		
0x0A	Channel 2 overcurrent threshold set to minimum current		
...	Channel 2 overcurrent threshold set to $I_{lim} = (\Delta I(LDK) \cdot n)$, n from 10 to 255		
0xFF	Channel 2 overcurrent threshold set to maximum current		

Table 15: Overcurrent threshold configuration channel 2

An overcurrent event can be simulated using $SOVCx$. If $SOVCx = 1$, the corresponding overcurrent error bit $OVCx$ will be set to 1, the error will be signaled at $NCHx$ and the corresponding laser channel will be disabled. The overcurrent error will remain forced until $SOVCx = 0$.

iC-HT DUAL CW LASER DIODE DRIVER

Rev C1, Page 17/46

SOVC1		Addr. 0x1D; bit 5	R/W 0
Code	Function		
0	No Overcurrent event at channel 1 is simulated.		
1	Overcurrent event at channel 1 simulated.		

Table 16: Simulate overcurrent channel 1

SOVC2		Addr. 0x1D; bit 6	R/W 0
Code	Function		
0	No overcurrent event at channel 2 is simulated.		
1	Overcurrent event at channel 2 simulated.		

Table 17: Simulate overcurrent channel 2

ACC (Automatic Current Control) mode

In this mode, the laser diode current is controlled and no monitor diode is required. ACC mode is selected setting EACCx register bit to 1.

EACC1		Addr. 0x10; bit 0	R/W 0
Code	Function		
0	APC mode enabled for channel 1		
1	ACC mode enabled for channel 1		

Table 18: APC/ACC in channel 1

EACC2		Addr. 0x15; bit 0	R/W 0
Code	Function		
0	APC mode enabled for channel 2		
1	ACC mode enabled for channel 2		

Table 19: APC/ACC in channel 2

In ACC mode the internal programmable logarithmic monitor resistor (PLR) is not used. Instead the internal RACCx resistor is used to set the current. For fine-tuning the regulated current, the reference voltage can be set with a 10 bit logarithmic D/A converter, which is configurable through the register REFx. This converter has a voltage range that goes typically from 0.1 V to 1.1 V, allowing an operation resolution of typically 0.235%. See page 27. Figure 9 shows an example of this configuration.

Two different current ranges can be set through register bit RACCx, with RACCx = 1 for up to 75 mA and with RACCx = 0 for up to 650 mA. The programmable overcurrent shutdown protects against over regulations during the laser power-on. Table 20 shows some typical current settings. For detailed limits, please refer to *Electrical Characteristics No. 114*

ACC typical current settings		
REFx	RACCx=0	RACCx=1
0x000	77.0 mA	9.06 mA
0x001	77.2 mA	9.08 mA
0x010	77.4 mA	9.10 mA
...
0x200	256.2 mA	30.14 mA
0x201	256.8 mA	30.21 mA
0x202	257.4 mA	30.28 mA
...
0x3FD	846.0 mA	99.53 mA
0x3FE	848.0 mA	99.77 mA
0x3FF	850.0 mA	100 mA

Table 20: ACC typical current settings

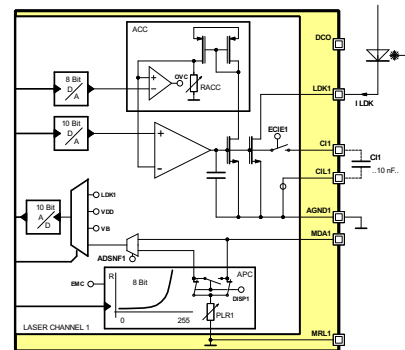

Figure 9: ACC mode simplified

RACC1		Addr. 0x1A; bit 0	R/W 0
Code	Function		
0	Current range high for channel 1		
1	Current range low for channel 1		

Table 21: RACC1 configuration

RACC2		Addr. 0x1A; bit 4	R/W 0
Code	Function		
0	Current range high for channel 2		
1	Current range low for channel 2		

Table 22: RACC2 configuration

In each range, the particular overcurrent threshold value can be set in register ILIMx. The regulator does differ the two current ranges in ACC.

Note: The accuracy of the overcurrent detection depends on the correct biasing of the driver stage. If the driver is saturated, the accuracy of the overcurrent

iC-HT DUAL CW LASER DIODE DRIVER

Rev C1, Page 18/46

detection is reduced and may not work as expected. Saturation voltage (*Electrical Characteristics No. 101*) must be ensured for a proper function of the overcurrent detection. LDKSAT1 and LDKSAT2 status bits can be used for anticipated saturation detection.

ILIM1	Addr. 0x11; bit 7:0	R/W 0xFF
Code	Function	
0x0A	Channel 1 overcurrent threshold set to minimum current	
...	Channel 1 overcurrent threshold set to $I_{lim} = (\Delta I / (LDK) \cdot n)$, n from 10 to 255	
0xFF	Channel 1 overcurrent threshold set to maximum current	

Table 23: Overcurrent threshold configuration channel 1

ILIM2	Addr. 0x16; bit 7:0	R/W 0xFF
Code	Function	
0x0A	Channel 2 overcurrent threshold set to minimum current	
...	Channel 2 overcurrent threshold set to $I_{lim} = (\Delta I / (LDK) \cdot n)$, n from 10 to 255	
0xFF	Channel 2 overcurrent threshold set to maximum current	

Table 24: Overcurrent threshold configuration channel 2

An overcurrent event can be simulated using bit SOVCx. If SOVCx = 1, the corresponding overcurrent error bit OVCx will be set to 1, the error will be signaled through NCHK and the corresponding laser channel will be disabled. The overcurrent error will remain forced until SOVCx = 0.

SOVC1	Addr. 0x1D; bit 5	R/W 0
Code	Function	
0	No overcurrent event at channel 1 is simulated.	
1	Overcurrent event at channel 1 simulated.	

Table 25: Simulate overcurrent channel 1

SOVC2	Addr. 0x1D; bit 6	R/W 0
Code	Function	
0	No overcurrent event at channel 2 is simulated.	
1	Overcurrent event at channel 2 simulated.	

Table 26: Simulate overcurrent channel 2

An external capacitor can be added in ACC mode in order to avoid oscillations as it is shown in Figure 9. The external Cx must be enabled setting the bit ECIEx (Tables 29 and 30).

In ACC mode, the MDAx pin can be monitored through a 10 bit A/D converter. This can be used for measuring the laser light power, if a photodiode is connected to pin MDAx, as it is shown in Figure 10. This allows adjusting the voltage reference in order to set the laser current and obtain the desired laser light power.

The internal programmable logarithmic monitor Resistor (PLR), if enabled (DISPx = 0), gives feedback for the current control through the 10 bit A/D converter. Register bit ADSNFx must be set to 1 in order to measure the internal sense node. An external monitor resistor can be used to measure the optical power, achieved by setting DISPx to 1. Therefore register bit ADSNFx must be set to 0 in order to measure directly at pin MDAx.

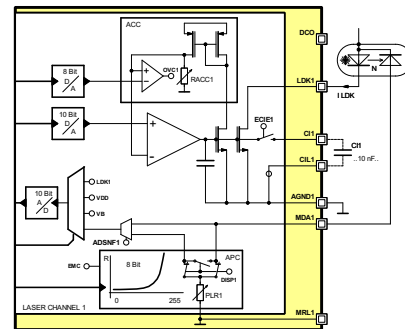

Figure 10: ACC with monitor photodiode

ACC mode permits to combine both channels in one iC-HT (see chapter COMBINING BOTH CHANNELS) and several iC-HT in parallel. When both channels are combined the programmable overcurrent shutdown is by channel. Another option is to connect the LDK together when both channels are configured in ACC mode and the channel 1 with high current range configuration and the channel 2 with low current range configuration. With this pre-sets there is a granularity about 0.2% using the channel 1 steps regulation and about 0.03% using the channel 2 in the regulation.

The Regulator

In MCU mode the control can be carried out without the need of external capacitor. This allows a fast response of the regulator. The speed of the regulator's response and stability can be configured using three bits (COMPx), providing a compensation factor.

iC-HT DUAL CW LASER DIODE DRIVER

Rev C1, Page 19/46

COMP1		Addr. 0x13; bit 6:4	R/W 011
Code	Function		
000	Minimum compensation for the channel 1 regulator, slower response of regulator		
...			
111	Maximum compensation for the channel 1 regulator, faster response of regulator		

Table 27: Regulator delay compensation channel 1

COMP2		Addr. 0x18; bit 6:4	R/W 011
Code	Function		
000	Minimum compensation for the channel 2 regulator, slower response of regulator		
...			
111	Maximum compensation for the channel 2 regulator, faster response of regulator		

Table 28: Regulator delay compensation channel 2

Alternatively it is possible to use external capacitors connected to pins Clx and CILx. In this case, register bit ECIE_x should be set to 1 and COMP_x to its highest value, "111".

ECIE1		Addr. 0x10; bit 1	R/W 0
Code	Function		
0	External Cl capacitor for channel 1 disconnected		
1	External Cl capacitor for channel 1 connected		

Table 29: Enable external capacitor channel 1

ECIE2		Addr. 0x15; bit 1	R/W 0
Code	Function		
0	External Cl capacitor for channel 2 disconnected		
1	External Cl capacitor for channel 2 connected		

Table 30: Enable external capacitor channel 2

The regulator is offset compensated in order to prevent optical power drifts. Offset compensation can be disabled by setting register bit EOC_x to 0.

EOC1		Addr. 0x10; bit 4	R/W 1
Code	Function		
0	Channel 1 regulator offset compensation disabled		
1	Channel 1 regulator offset compensation enabled		

Table 31: Enable offset compensation channel 1

EOC2		Addr. 0x15; bit 4	R/W 1
Code	Function		
0	Channel 2 regulator offset compensation disabled		
1	Channel 2 regulator offset compensation enabled		

Table 32: Enable offset compensation channel 2

An internal oscillator is used for the offset compensation. A watchdog timer (WDT) is included in order to monitor proper function of the oscillator. If an error is detected by the WDT, the laser channels are disabled, OSCERR error bit is set in STATUS0 register and the error event is signaled at pin NCHK. This error signaling can be suppressed using the mask register bit MOSCERR (set to 1).

MOSCERR		Addr. 0x1D; bit 0	R/W 0
Code	Function		
0	Oscillator error (watchdog) will be signaled at NCHK		
1	Oscillator error (watchdog) will not be signaled at NCHK		

Table 33: Oscillator error mask

iC-HT monitors the saturation voltage of the regulator's output transistor at pin LDK_x. The LDK saturation threshold can be configured through register bits RLDKS_x.

RLDKS1		Addr. 0x13; bit 3:2	R/W 00
Code	Function		
00	V(LDK1) < 0.5 V sets the LDKSAT1 alarm bit		
01	V(LDK1) < 0.8 V sets the LDKSAT1 alarm bit		
10	V(LDK1) < 1.0 V sets the LDKSAT1 alarm bit		
11	V(LDK1) < 1.2 V sets the LDKSAT1 alarm bit		

Table 34: LDK saturation threshold selection channel 1

RLDKS2		Addr. 0x18; bit 3:2	R/W 00
Code	Function		
00	V(LDK2) < 0.5 V sets the LDKSAT2 alarm bit		
01	V(LDK2) < 0.8 V sets the LDKSAT2 alarm bit		
10	V(LDK2) < 1.0 V sets the LDKSAT2 alarm bit		
11	V(LDK2) < 1.2 V sets the LDKSAT2 alarm bit		

Table 35: LDK saturation threshold selection channel 2

If the LDK_x voltage falls below the LDK saturation threshold the LDKSAT_x error bit in STATUS1 register will be set and it will be signaled through output pin NCHK. Setting the mask register bit MLDKSAT_x to 1 suppresses the signaling at NCHK.

MLDKSAT1		Addr. 0x1D; bit 2	R/W 1
Code	Function		
0	LDKSAT1 event will be signaled at NCHK		
1	LDKSAT1 event will not be signaled at NCHK		

Table 36: LDK saturation mask channel 1

iC-HT

DUAL CW LASER DIODE DRIVER

Rev C1, Page 20/46

MLDKSAT2		Addr. 0x1D; bit 3	R/W 1
Code	Function		
0	LDKSAT2 event will be signaled at NCHK		
1	LDKSAT2 event will not be signaled at NCHK		

Table 37: LDK saturation mask channel 2

Laser channel enabling and error handling

With pin INS/WKR or EMC unconnected, a corresponding error signal will be generated (INSOPEN, EMCOPEN) and will disable the laser channels. Any input interface could be enabled if EMC or INS pins are open. Communication with the chip might be possible but laser

cannot be switched on. This situation is only signaled at the MCU interruption pin NCHK, which would remain low as long as any of the EMC or INS pins are unconnected. MCU must monitor the status of the pin NCHK to get all the status information of the chip

Setting DISC1 and DISC2 to 1(default) disables the corresponding channel.

The errors in STATUS0 and STATUS1 registers disable the laser channels. Every change in the STATUS registers is signaled at pin NCHK, unless the error event is masked by the corresponding error mask bit.

Register	Address	Bits	Default	Description
INITRAM	0x00	0	R/O	RAM initialized.
PDOVDD	0x00	1	R/O	Power down event at VDD
MEMERR	0x00	2	R/O	RAM memory validation error
OVT	0x00	3	R/O	Overtemperature event
OVC2	0x00	4	R/O	Overcurrent at channel 2
OVC1	0x00	5	R/O	Overcurrent at channel 1
OSCERR	0x00	6	R/O	Oscillator error (watchdog set)
CFGTIMO	0x00	7	R/O	Configuration mode timeout event
MAPC1	0x01	0	R/O	Channel 1 current state (on or off)
MONC1	0x01	1	R/O	Monitor channel 1 enabled at least once (latched)
LDKSAT1	0x01	2	R/O	Channel 1 LDK saturation event
MAPC2	0x01	4	R/O	Channel 2 current state (on or off)
MONC2	0x01	5	R/O	Monitor channel 2 enabled at least once (latched)
LDKSAT2	0x01	6	R/O	Channel 2 LDK saturation event

Table 38: Status registers overview

In order to enable the channels, the error events must be acknowledged. Acknowledging an error is accomplished by reading the STATUS register. After a power-on PDVDD and INITRAM errors will be set, therefore it is required to read STATUS0 and STATUS1 registers after each power-on.

Exiting standby mode will not reset the RAM but will set the PDOVDD status bit. Therefore STATUS0 must

be read once after each standby to re-enable the laser channels.

In case of an overcurrent (OVC) or an overtemperature (OVT) event, laser channels are disabled.

A memory error event and a configuration timeout error event will also disable the laser channels. See page 34. The conditions to enable each laser channel are shown in Figure 11.

iC-HT DUAL CW LASER DIODE DRIVER

Rev C1, Page 21/46

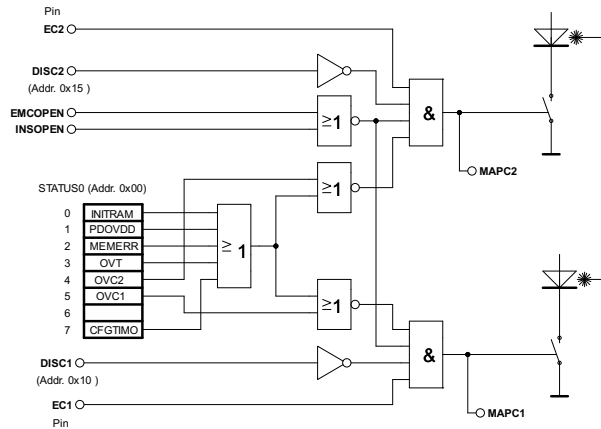

Figure 11: Laser control logic in MCU mode

The events that require user attention are signalled as a low level at pin NCHK. Some of these events are considered as non-critical and can be masked. Figure 12 shows the logical function of NCHK. As a safety feature, some critical events (Laser overcurrent, sys-

tem overtemperature, local oscillator malfunction) can be simulated by the user. This eases the debugging of applications where the reaction in case of critical events is important.

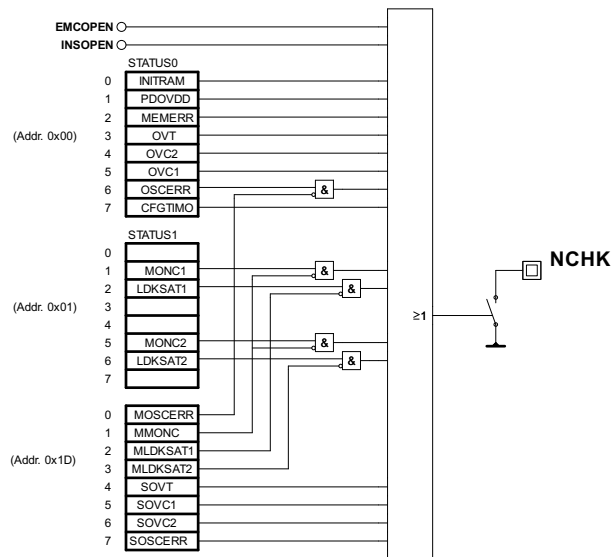

Figure 12: NCHK function in MCU mode

iC-HT DUAL CW LASER DIODE DRIVER

Rev C1, Page 22/46

COMBINING BOTH CHANNELS

iC-HT can drive one laser diode up to 1500 mA with both channels combined.

Therefore register bit MERGE must be set to 1. Disable channel register bits DISC1 and DISC2 must both be set to 0 and both enable channel pins EC1 and EC2 must be set hi.

MERGE		Addr. 0x1B; bit 6	R/W 0
Code	Function		
0	Channel 1 and 2 operate independently		
1	Power transistor from channel 2 in parallel with channel 1, controlled by channel 1		

Table 39: Channel merging

ACC typical current settings with MERGE = 1

REF1	RACCx=0 RMERGE=1	RACCx=1 MERGE=1
0x000	144.0 mA	18.12 mA
0x001	144.4 mA	18.16 mA
0x010	144.8 mA	18.20 mA
...
0x200	512.4 mA	60.28 mA
0x201	513.6 mA	60.42 mA
0x202	514.8 mA	60.56 mA
...
0x3FD	1692.0 mA	199.54 mA
0x3FE	1696.0 mA	199.54 mA
0x3FF	1700.0 mA	200 mA

Table 40: ACC typical current settings with MERGE = 1

When both channels are combined the control is done by channel 1. APC and ACC can both be used with both channels combined. In ACC mode, the reference needs to be set to 50% of the desired current value. This is not required for APC.

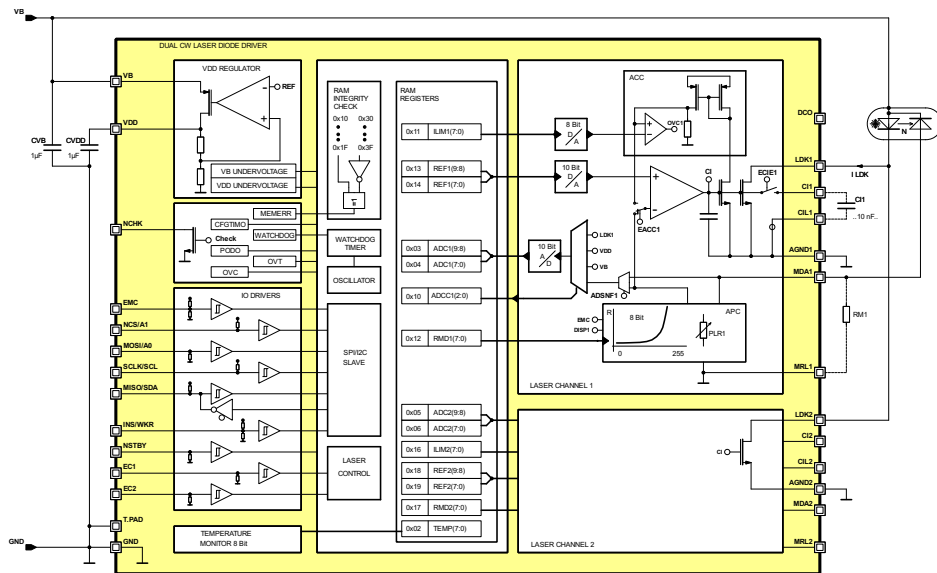

Figure 13: Combining both channels

In combined mode, the internal CI nodes of both channels are connected together. If required, an external capacitor on channel 1 can be used for improved stability. It is possible to have an additional external capacitor on channel 2, if ECIE2 bit is set to 1. Having an exter-

nal capacitor on channel 2 and none on channel 1 is invalid.

On combined operation both overcurrent thresholds are active. The overcurrent threshold channel 1 needs to

iC-HT DUAL CW LASER DIODE DRIVER

Rev C1, Page 23/46

be set to 50% and the overcurrent threshold channel 2 should be disabled by setting it to its maximum value (0xFF). An overcurrent will only be detected on channel 1.

It is possible to use a second photodiode connected to channel 2 (e.g. as a safety supervisor). The ADC on channel 2 can be used to monitor the voltage at pin MDA2, as it is shown in Figure 14.

ILIM1	Addr. 0x11; bit 7:0	R/W 0xFF
Code	Function	
0x0A	Channel 1 overcurrent threshold: 80 mA, MERGE=1	
...	Channel 1 overcurrent threshold set to $I_{lim} = (2 * \Delta I(LDK) * n)$, n from 10 to 255, MERGE=1	
0xFF	Channel 1 overcurrent threshold: 2040 mA, MERGE=1	

Table 41: Overcurrent threshold configuration channel 1 with MERGE = 1

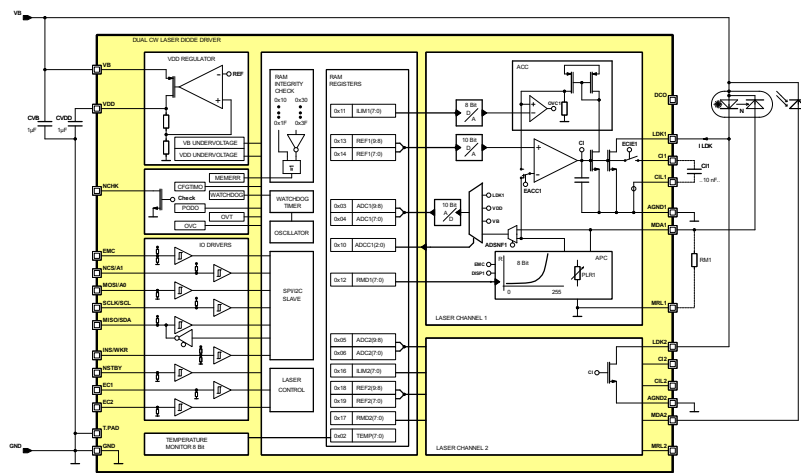

Figure 14: Additional photodiode in combined configuration

IC-HT

DUAL CW LASER DIODE DRIVER

Rev C1, Page 24/46

SERIAL COMMUNICATION INTERFACES

SPI slave interface

The SPI slave interface is enabled by setting pin INS/WKR to lo and uses pins NCS/A1, SCLK/SCL, MISO/SDA and MOSI/A0. Pin NCS/A1 is the chip select pin and must be set lo by the SPI master in order to start communication. Pins MISO/SDA and MOSI/A0 are the data communication lines and pin SCLK/SCL is the clock line generated by the SPI master (e.g. microcontroller). The SPI protocol frames are shown in Figure 15.

A communication frame consists of one address byte and at least one data byte. Bits 7:6 of the address byte is the opcode used for selecting a read operation (set to "10") or a write (set to "01") operation. The remaining 6 bits are used for register addressing.

It is possible to transmit several bytes consecutively, if the NCS signal is not reset and SCLK/SCL keeps clocking, as it is shown in Figure 15. The address is internally incremented after each transmitted byte. Once the address reaches the last register (0x3F), it is reset back to 0x00.

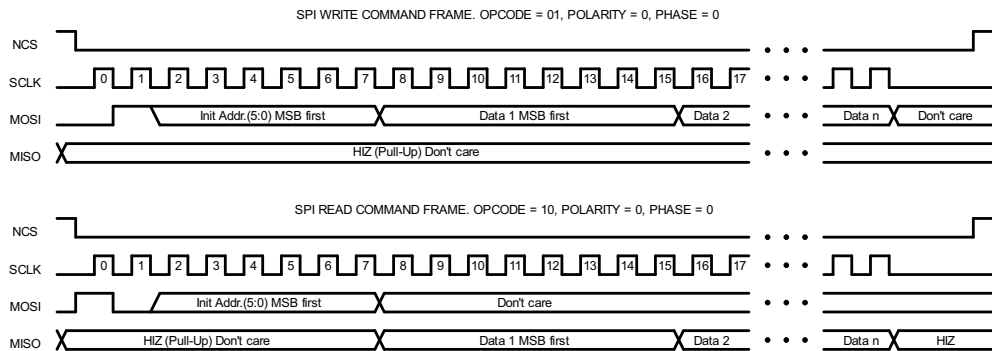

Figure 15: SPI read and write commands

I²C slave interface

The I²C slave interface is enabled by setting pin INS/WKR to hi and uses pins NCS/A1, SCLK/SCL, MISO/SDA and MOSI/A0. The protocol frames are shown in Figure 16.

Action	b7	b6	b5	b4	b3	b2	b1	b0
Write to slave	1	1	0	0	0	A1	A0	0
Read from slave	1	1	0	0	0	A1	A0	1

Table 42: I²C write/read byte

A communication frame consists of one slave address byte, one register address byte and at least one data byte. Bits 7:1 of the slave address byte form the slave identification code (ID) and bit 0 is used for specification of the data direction (0 for write, 1 for read). The slave ID consists of 7 bits. The five most significant bits are fixed by default to value 0b11000. Pins MOSI/A0 and NCS/A1 are used to set the remaining slave ID bits (see Table 42 and 43).

Action	A1	A0	Slave ID	Address byte
Write to slave 0	lo	lo	0x60	0xC0
Read from slave 0	lo	lo	0x60	0xC1
Write to slave 1	lo	hi	0x61	0xC2
Read from slave 1	lo	hi	0x61	0xC3
Write to slave 2	hi	lo	0x62	0xC4
Read from slave 2	hi	lo	0x62	0xC5
Write to slave 3	hi	hi	0x63	0xC6
Read from slave 3	hi	hi	0x63	0xC7

Table 43: I²C write/read address

iC-HT DUAL CW LASER DIODE DRIVER

Rev C1, Page 25/46

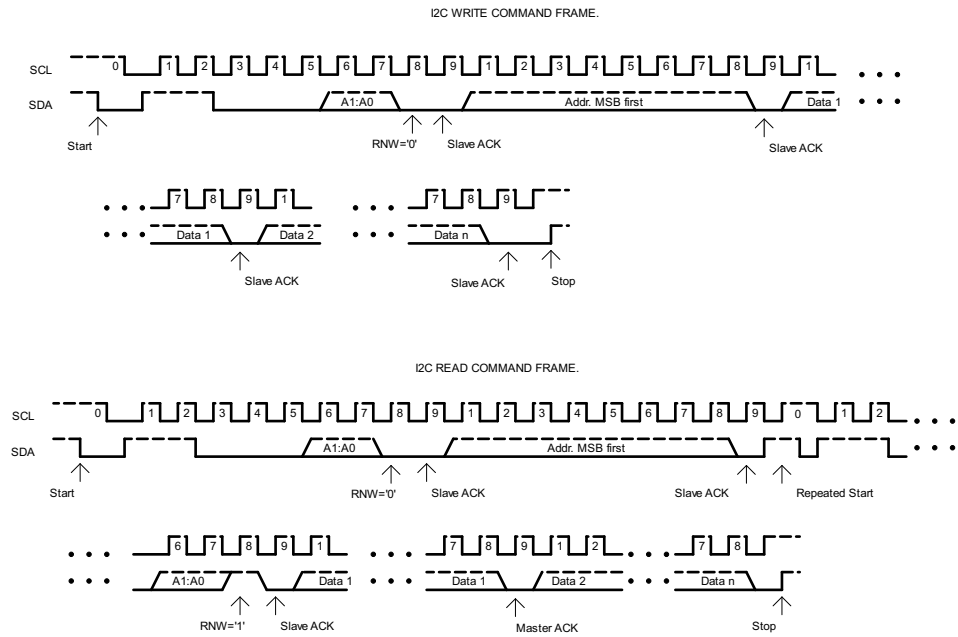

Figure 16: I²C read and write commands

iC-HT

DUAL CW LASER DIODE DRIVER

Rev C1, Page 26/46

8 BIT INTERNAL PROGRAMMABLE LOGARITHMIC MONITOR RESISTORS

In MCU mode internal 8 bit programmable logarithmic monitor resistors (PLRx) are provided for APC.

The resistor value can be selected from 256 values, ranging from 100 Ω to 500 kΩ, following logarithmic increments with a typical step width of 3.3%. The resistors are configured with registers RMDx(7:0).

RMD1		Addr. 0x12; bit 7:0	R/W 0xFF
Code	Function		
0x00	PLR1 set to the minimum resistance		
...	PLR1 set to		
	$Rmd = Rmd_0(1 + \frac{\Delta Rmd(\%)}{100})^{n+1}$, n from 0 to 255		
0xFF	PLR1 resistor set to the maximum resistance		

Table 44: MDA resistor channel 1

RMD2		Addr. 0x17; bit 7:0	R/W 0xFF
Code	Function		
0x00	PLR2 resistor set to the minimum resistance		
...	PLR2 set to		
	$Rmd = Rmd_0(1 + \frac{\Delta Rmd(\%)}{100})^{n+1}$, n from 0 to 255		
0xFF	PLR2 resistor set to the maximum resistance		

Table 45: MDA resistor channel 2

The following formula calculates the register RMDx in order to set the desired resistor value:

$$Rmd = Rmd_0(1 + \frac{\Delta Rmd(\%)}{100})^{n+1}, n \text{ from } 0 \text{ to } 255$$

Where Rmd_0 is the minimum resistor value (typically 100 Ω), $\Delta Rmd(\%)$ is the step between two consecutive resistor values (typically 3.3%) and n is the value of RMDx register in decimal.

In APC mode the regulation node is the internal connection to PLR, it is not MDAX pin (see detail in Figure 17). Voltage present at pin MDAX may differ from the internal regulation node. This regulation node can be sensed through the 10 bit A/D converter and read at register ADCx. Register bit ADSNFx must be set to 1 for this purpose. If ADSNFx is set to 0, MDAX pin will be the input of the A/D converter.

At pin MDAX only the 4 MSB of the RMDx configuration from PLRx are measurable. The 8 bits of the PLRx configuration RMDx can be measured with the A/D converter setting ADSNFx to 1.

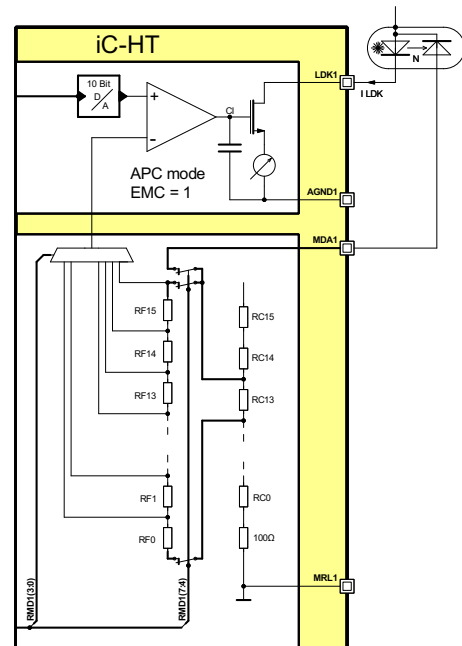

Figure 17: PLR internal node regulation

With $DISPx = 0$ the PLRx is enabled and $DISPx = 1$ disables the PLRx.

DISP1		Addr. 0x10; bit 2	R/W 0
Code	Function		
0	PLR enabled for channel 1		
1	PLR disabled for channel 1		

Table 46: Disable PLR channel 1

DISP2		Addr. 0x15; bit 2	R/W 0
Code	Function		
0	PLR enabled for channel 2		
1	PLR disabled for channel 2		

Table 47: Disable PLR channel 2

In ACC mode the PLR is not used in the control circuit. Instead, the internal RACCx resistor is used in the control loop.

Even though the PLR is not in the control circuit, it can be enabled ($DISPx = 0$) in order to give feedback

iC-HT DUAL CW LASER DIODE DRIVER

Rev C1, Page 27/46

through the 10 bit A/D converter for controlling the optical power, if a monitor diode is connected.

can be used to measure the optical power, by setting DISPx to 1. Then register bit ADSNF must be set to 0 in order to measure directly at pin MDAx.

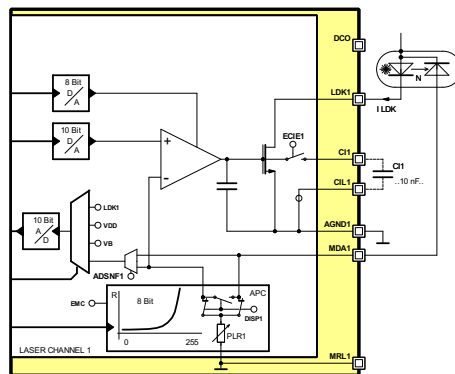

Figure 18: PLR in APC

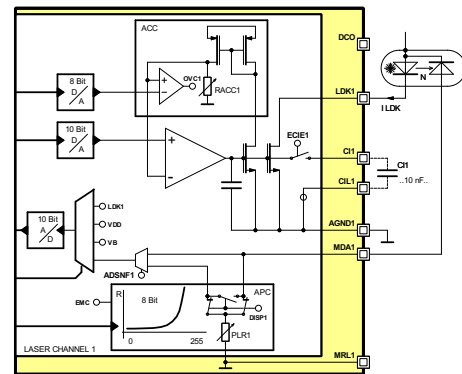

Figure 19: ACC with monitor photodiode

Register bit ADSNF is set to 1 to measure the internal sense node. Alternatively, an external monitor resistor

10 BIT LOGARITHMIC D/A CONVERTER

The 10 bit logarithmic D/A converter is used for setting the regulator's voltage reference. The D/A converter is active in all operating modes. In iC-WK mode only two values are available: 0.25 V (setting INS/WKR pin lo) and 0.5 V (setting INS/WKR pin hi). In MCU mode both APC and ACC use the D/A converter. With a range from 0.1 to 1.1 V and the typical step width is 0.235%.

The D/A converter is configured through register REFx(9:0). With REFx(9:0) = 0x000, D/A output value is set to 0.1 V, and for REFx(9:0) = 0x3FF, D/A output is configured to 1.1 V.

REF1	Addr. 0x13/14; bit 9:0	R/W 0x000
Code	Function	
0x000	Channel 1 regulator reference voltage set to minimum voltage	
...	Channel 1 regulator reference voltage set to $Vref = Vref_0(1 + \frac{\Delta Vref(\%)}{100})^{n+1}$, n from 0 to 1023	
0x3FF	Channel 1 regulator reference voltage set to maximum voltage	

Table 48: Channel 1 regulator voltage reference

REF2	Addr. 0x18/19; bit 9:0	R/W 0x000
Code	Function	
0x000	Channel 2 regulator reference voltage set to minimum voltage	
...	Channel 2 regulator reference voltage set to $Vref = Vref_0(1 + \frac{\Delta Vref(\%)}{100})^{n+1}$, n from 0 to 1023	
0x3FF	Channel 2 regulator reference voltage set to maximum voltage	

Table 49: Channel 2 regulator voltage reference

To calculate the D/A converter value for each REFx value, use the following formula:

$$Vref = Vref_0(1 + \frac{\Delta Vref(\%)}{100})^{n+1}, n \text{ from } 0 \text{ to } 1023$$

Where $Vref_0$ is the minimum value (typically 0.1 V), $\Delta Vref(\%)$ is the step value (typically 0.235%) and n is the value of REFx register in decimal.

iC-HT

DUAL CW LASER DIODE DRIVER

Rev C1, Page 28/46

10 BIT LINEAR A/D CONVERTER

A 10 bit linear A/D converter is available for each channel when working in MCU mode. A variety of voltages can be measured by the converter with two resolutions:

- V(LDKx) up to 8 V with 8.6 mV resolution
- V(VDD) up to 8 V with 8.6 mV resolution
- V(VB) up to 8 V with 8.6 mV resolution
- V(MDAx) up to 1 V with 1.075 mV resolution
- V(PLRx) up to 1 V with 1.075 mV resolution

Note that when the value to be converted is higher than 8 V the A/D converter is saturated at its highest conversion value.

The register bits ADCCx select the signal measured with the 10 bit A/D converter.

ADCC1(2:0)		Addr. 0x10; bit 7:5	R/W 000
Code	Function		
0xx	Channel 1 ADC disabled		
100	Channel 1 ADC sourced by V(MDA1), ADSNF1 = 0		
100	Channel 1 ADC sourced by V(PLR1), ADSNF1 = 1		
101	Channel 1 ADC sourced by V(VB)		
110	Channel 1 ADC sourced by V(VDD)		
111	Channel 1 ADC sourced by V(LDK1)		

Table 50: ADC channel 1 source selection

ADCC2(2:0)		Addr. 0x15; bit 7:5	R/W 000
Code	Function		
0xx	Channel 2 ADC disabled		
100	Channel 2 ADC sourced by V(MDA2), ADSNF2 = 0		
100	Channel 2 ADC sourced by V(PLR2), ADSNF2 = 1		
101	Channel 2 ADC sourced by V(VB)		
110	Channel 2 ADC sourced by V(VDD)		
111	Channel 2 ADC sourced by V(LDK2)		

Table 51: ADC channel 2 source selection

With ADCCx(2:0) = 100, the signal to the A/D converter is selected by register bit ADSNFx (A/D converter sense not force). With ADSNFx = 1 the measuring point to the A/D converter is the internal sense node of the internal programmable logarithmic monitor resistor (PLR). With ADSNFx = 0 the sensing point is connected directly to MDAx pin.

ADSNF1		Addr. 0x1A; bit 2	R/W 0
Code	Function		
0	ADC measurement MDA1 pin (force)		
1	ADC measurement PLR1 (sense)		

Table 52: ADC channel 1 sense/force selection

ADSNF2		Addr. 0x1A; bit 6	R/W 0
Code	Function		
0	ADC measurement MDA2 pin (force)		
1	ADC measurement PLR2 (sense)		

Table 53: ADC channel 2 sense/force selection

When enabled, the A/D converter is continuously acquiring the signal selected by ADCCx register. The conversion time, is 140 µs. Changing the source requires 500 µs settling time.

In order to do a measurement, register ADCx must be read. The converter does not provide an end of conversion (EOC) bit. Instead, ADCx register contains always the value of the last conversion.

The A/D converter must be stopped before the result can be read to prevent measurement change during MSB and LSB readout. This can be done by setting the ADCCx MSB to 0. The procedure is as follows:

1. Set ADCCx to the desired input source with the ADC disabled (ADCCx, bit 2 set to 0).
2. Start ADC conversion (ADCCx, bit 2 set to 1).
3. Wait for the settling time (Item. 701, up to 500µs).
4. Stop the ADC (ADCCx, bit 2 set to 0).
5. Read the ADC data.
6. If ADC input source doesn't need to be changed, repeat from 2..

ADC1		Addr. 0x03/04; bit 9:0	R
Code	Function		
0x000	ADC minimum value		
0x3FF	ADC maximum value		

Table 54: ADC channel 1

ADC2		Addr. 0x05/06; bit 9:0	R
Code	Function		
0x000	ADC minimum value		
0x3FF	ADC maximum value		

Table 55: ADC channel 2

The voltage corresponding to the measured digital value can be directly obtained through the following formula:

$$V(LDKx, VB, VDD) = 8 * \frac{VFS}{1023} * ADCx$$

iC-HT DUAL CW LASER DIODE DRIVER

Rev C1, Page 29/46

$$V(MDAX, PLRx) = \frac{VFS}{1023} * ADCx$$

VFS is the fullscale voltage of the A/D converter (cf. *Electrical Characteristics No. 706*) typical 1.1 V. For a more precise measurement, the A/D converter can be calibrated by measuring a known VB voltage and calculate the VFS.

If ADSNFx = 0 the sensing point is connected directly to pin MDAX. Depending on the regulation voltage, it is possible that V(MDAX) is higher than 1.1 V. When pin MDAX is the source of the A/D converter, saturation of the converter will occur. When monitoring pin MDAX with the A/D converter, V(MDAX) must be lower than 1.1 V.

DC/DC CONVERTER OPTIMIZATION

iC-HT provides a 6 bit configurable current at pin DCO that can be used to trim the output voltage of a DC/DC converter.

Possible application benefits with using DCO:

- DC/DC step down operation: regulation at voltages lower than power supply
- DC/DC step up operation: regulation at voltages higher than power supply
- Efficiency enhancement

RDCO		Addr. 0x1B; bit 5:0	R/W 0x02
Code	Function		
0x00	No current		
...			
0x3F	130 µA typ (cf. <i>Electrical Characteristics No. D01</i>)		

Table 56: Digital current output register

The proposed applications can be demonstrated with a standard DC/DC converter e.g. TPS63060DSC from Texas Instruments. This converter allows an input voltage ranging from 2.5 to 12 V and offers an output voltages from 2.5 to 8 V. It is capable of delivering up to 2 A current, depending on the output voltage. Figure 20 shows a possible configuration.

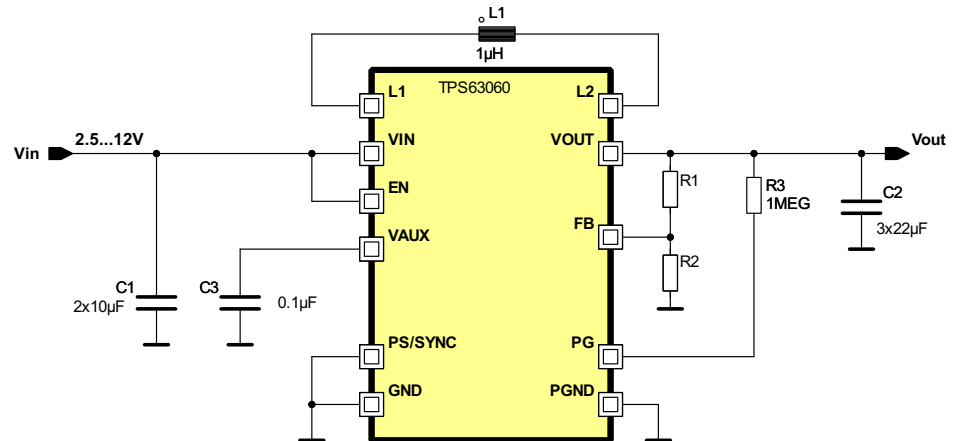

Figure 20: TPS63063 DC/DC converter from TI

DC/DC step down operation: regulation at voltages lower than power supply

The resistors R1 and R2 in the feedback path allow setting the desired output value Vout. The DC/DC converter drives Vout pin in order to yield 0.5 V at feedback pin FB. The DCO output signal from iC-HT is connected

to FB pin. The Vout is controlled with the internal register RDCO from iC-HT.

The DCO current into FB node controls the voltages of the divider R1 and R2 and Vout changes in order to maintain 0.5 V at FB pin. Selecting R1 and R2 needs to consider:

iC-HT DUAL CW LASER DIODE DRIVER

Rev C1, Page 30/46

- Resistors values:
 $R1 = R2 \left(\frac{V_{out}}{V_{in}} - 1 \right)$
- Current of the voltage divider should be high enough, in comparison to the current from the pin DCO, to offer acceptable resolution. The programmable current resolution from register RDCO is $2 \mu A$.
- DCO current into the voltage divider will lower V_{out} voltage, V_{out} is 8V when no current is present at DCO.

The value in RDCO register needed in order to have the desired output voltage can be calculated using the following formula:

$$RDCO = \frac{I_{dco}}{2 \mu A} = \frac{IR2 - IR1}{2 \mu A} = \frac{0.5 - \frac{V_{out} - 0.5}{100k}}{2 \mu A}$$

The resulting value will vary slightly depending on the tolerances of the selected resistors and DCO current.

The voltage is reduced from 8V ($RDCO = 0$) to 2.5V, when $RDCO = 27$.

Choosing $R1$ to 100kΩ, the value of $R2$ can be calculated:

$$R2 = \frac{R1}{\frac{V_{out}}{V_{in}} - 1} = \frac{100k}{\frac{8}{3} - 1} = 6.7k\Omega$$

With this configuration the current through the voltage divider is $75 \mu A$ at 8V. The resolution of each RDCO step is then 200mV.

DC/DC step up operation: regulation at voltages higher than power supply

A practical application of the present case is the control of blue lasers. This type of laser present a forward voltage around 5V, which demands an LDA voltage of about 6V. If the system is supplied with a 3V LiPo battery, it is necessary to use a the DC/DC in order to step up and drive the laser diode and driver with a sufficient voltage. Figure 21 shows this application:

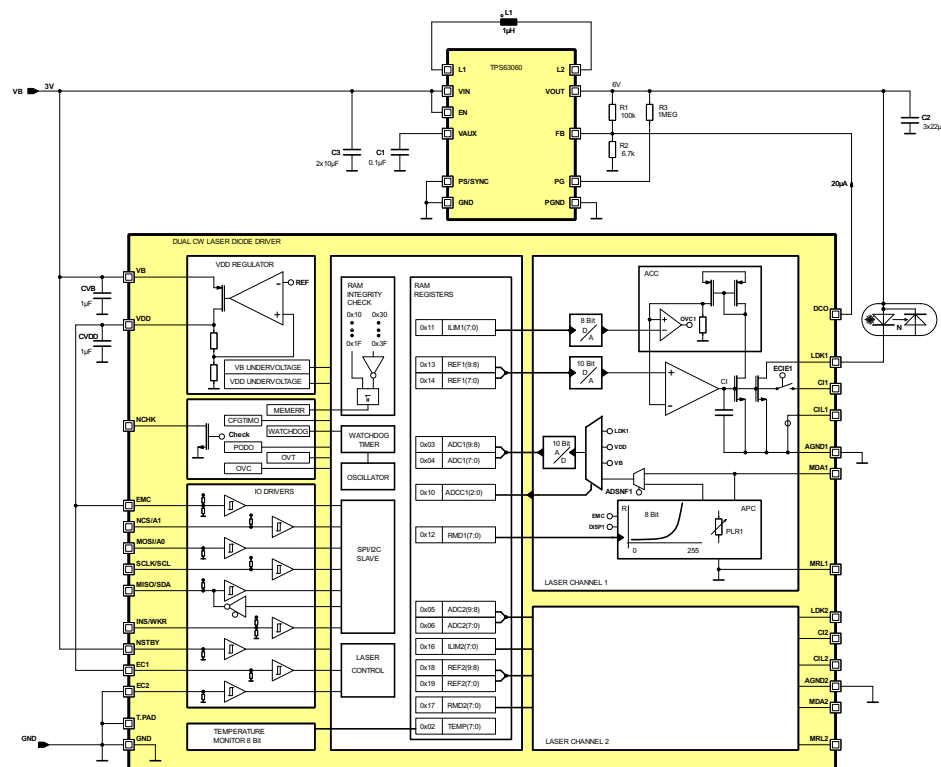

Figure 21: Regulation at voltage greater than power supply

iC-HT DUAL CW LASER DIODE DRIVER

Rev C1, Page 31/46

Setting register RDCO to 10 it delivers 20 μA and 6 V are obtained at Vout.

old values of 2.8 and 8 V. It is possible to control the DC/DC output in a voltage range of 2.5 to 12 V if the DC/DC converter, controlled by DCO output signal, is included in the system, as it is shown in Figure 22:

Extension of system working voltage range
iC-HT must be supplied by a voltage within the thresh-

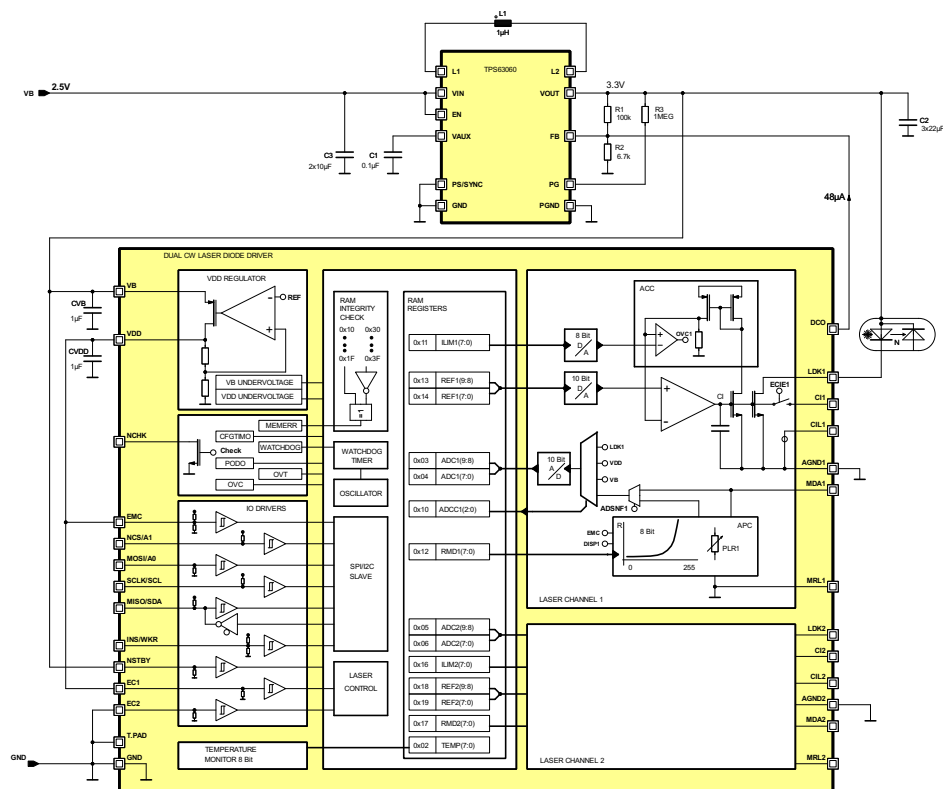

Figure 22: Extension of working voltage range

In the Figure 22 both the laser and the iC-HT are supplied by output voltage Vout from DC/DC converter. The register RDCO is set to 23, which forces 48 μA to be output to the voltage divider. A system voltage of 3.3 V is obtained at Vout.

depending on the supplied voltage, the saturation voltage and the laser diodes forward voltage. Power dissipation of the driver can be reduced if LDAX is fed through the DC/DC converter configured to deliver a lower voltage than the power supply as shown in Figure 23.

Efficiency enhancement

If iC-HT and the laser diode are supplied with the same power supply, the efficiency of the driver can be poor,

iC-HT
DUAL CW LASER DIODE DRIVER

Rev C1, Page 32/46

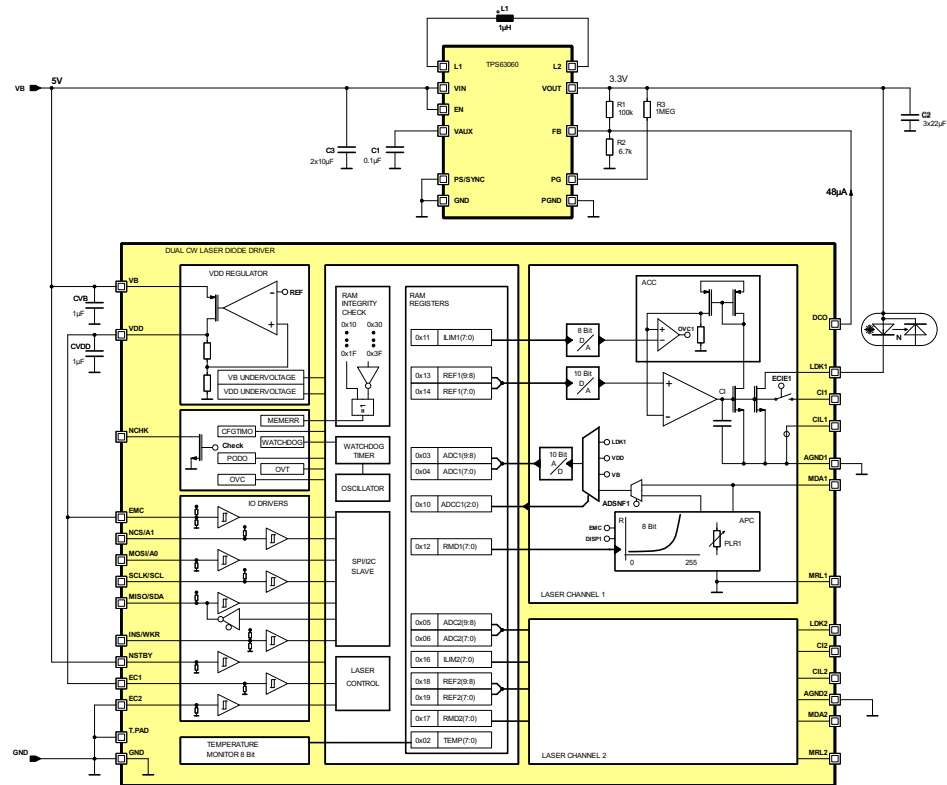

Figure 23: System efficiency enhancement

The register RDCO is set to 23 to provide a laser diode supply voltage of 3.3V at Vout.

WATCHDOG TIMER

The internal 200 kHz oscillator is monitored with the Watchdog Timer (WDT).

If the oscillator remains longer than the maximum time of tWDT (cf. *Electrical Characteristics No. E03*) without activity an oscillator error is triggered. An oscillator error sets OSCERR error bit to 1. The automatic offset compensation of the laser control requires the oscillator.

The state of OSCERR is signaled at pin NCHK. The signaling of OSCERR state can be masked with bit MOSCERR. Setting MOSCERR to 1 masks the oscillator error and OSCERR will not be signaled at NCHK.

It is possible to simulate an error of the oscillator using SOSCERR bit. If SOSCERR = 1, the oscillator error is forced. When OSCERR is set to 1 the error will be signaled through NCHK, depending on the state of MOSCERR.

OSCERR		Addr. 0x00; bit 6	R
Code	Function		
0	Oscillator operates OK		
1	Watchdog timeout set on oscillator failure		

Table 57: Oscillator error

iC-HT DUAL CW LASER DIODE DRIVER

Rev C1, Page 33/46

MOSCERR		Addr. 0x1D; bit 0	R/W 0
Code	Function		
0	Oscillator error (watchdog) will be signaled at NCHK		
1	Oscillator error (watchdog) will not be signaled at NCHK		

Table 58: Oscillator error mask

SOSCERR		Addr. 0x1D; bit 7	R/W 0
Code	Function		
0	No oscillator error simulated		
1	Oscillator error simulated (watchdog timeout)		

Table 59: Simulate oscillator error

TEMPERATURE MONITOR AND PROTECTION

iC-HT includes an 8 bit temperature monitor that allows to measure the internal chip temperature going from -40 to 125 °C. The resolution is 1 °C/LSB. The internal temperature can be obtained by reading register TEMP. TEMP is a read-only register.

TEMP		Addr. 0x02; bit 7:0	R
Code	Function		
0x00	Minimum temperature		
...			
0xFF	Maximum temperature		

Table 60: Chip temperature

Absolute read values may differ from one chip to another. An individual initial calibration of the temperature monitor is recommended. The TEMP register must be read at a known temperature. Using the resolution value of 1 °C/LSB, the internal temperature can be calculated.

The temperature monitor can be used to compensate temperature effects on the laser diode. The microcontroller can use a laser diode characteristic formula or a look-up table combined with the temperature value measured through register TEMP. The reference voltage can be configured accordingly in order to compensate temperature effects.

iC-HT is protected against overtemperature. In iC-WK mode, if the internal temperature value exceeds the overtemperature threshold an OVT error event will be triggered and signaled through pin NCHK. Both laser channels will be disabled. Pin NCHK will keep signaling the error although the internal temperature goes down to a safe value below the overtemperature threshold value. If the temperature has exceeded the overtemperature threshold value, pins EC1 and EC2 have to be

pulled lo in order to stop signaling the error. Setting pin ECx back hi will re-enable the corresponding channel.

In microcontroller mode, if the internal temperature exceeds a safety value an overtemperature error bit (OVT) will be set to 1. If OVT = 1, both channels will be disabled and the error event will be signaled through pin NCHK. If the internal temperature goes down to a safe value below the overtemperature threshold value, OVT will remain at value 1. Reading the OVT bit stop signaling error through pin NCHK. Reading OVT bit will set it back to 0. Setting pin ECx lo and then back hi will allow re-enabling the corresponding channel.

The overtemperature threshold value can not be configured.

OVT		Addr. 0x00; bit 3	R
Code	Function		
0	No overtemperature event has occurred since last read		
1	Overtemperature event has occurred. Cleared on read		

Table 61: Overtemperature detection

In microcontroller mode it is possible to simulate an overtemperature event using bit SOVT. Setting SOVT to 1, the overtemperature error flag OVT will be set to 1. iC-HT will remain in error state until SOVT is set back to 0.

SOVT		Addr. 0x1D; bit 4	R/W 0
Code	Function		
0	No overtemperature event is simulated.		
1	Overtemperature event simulated.		

Table 62: Simulate overtemperature

iC-HT

DUAL CW LASER DIODE DRIVER

Rev C1, Page 34/46

DIGITAL INTERFACE AND MEMORY INTEGRITY MONITOR

iC-HT provides a microcontroller slave interface by selection on the EMC pin. iC-HT support the interfaces SPI or I²C that are selected by the INS/WKR pin.

EMC		Addr. Pin;
Code	Function	
lo	iC-WK-mode, digital interfaces disabled	
Open	Not allowed, error signaled	
hi	MCU mode, interface selected by INS/WKR enabled	

Table 63: Enable microcontroller

INS/WKR		Addr. Pin;
Code	Function	
lo	SPI interface selected	
Open	Not allowed, error signaled.	
hi	I ² C interface selected	

Table 64: Interface selection I²C or SPI

The configuration memory is integrity monitored and **atomic executable** (all at once: changes of the configurations without any direct effects, the changes are executed at once by command) to the functional blocks of iC-HT.

Integrity monitoring is implemented by a duplication of the configuration registers into a validation page (see description below) where the register are automatically copied with inverted value. Every register bit is compared with its validation copy and in case of difference, a memory error is generated and both laser channels are switched off.

Atomic appliance is achieved by latching the configuration registers. This permits a full configuration (different

registers) to be made prior to apply it to the laser channels. iC-HT has two different modes selectable by the MODE(1:0) register (address 0x1C).

MODE(1:0)		Addr. 0x1C; bit 1:0	R/W 01
Code	Function		
00	Invalid parameter		
01	Operation mode		
10	Configuration mode		
11	Invalid parameter		

Table 65: Configuration and operation mode

In **Configuration mode**, the *configuration memory* (address 0x10 to 0x1F) can be written and read back to check a correct communication without changing the present configured operation state of the iC-HT. In this mode, the memory integrity check is disabled.

iC-HT will monitor the time elapsed in configuration mode and automatically switch the laser off if it exceeds a configuration mode timeout. The time in configuration mode must less than 40 ms for ensuring that no configuration timeout occurs during configuration (cf. *Electrical Characteristics No. E02*). The timeout can be up to 164 ms.

When writing the configuration is completed, iC-HT is switched to **operation mode** by writing "0b01" into the MODE register (address 0x1C). In **operation mode** the configuration is applied to the iC-HT and the memory integrity check activated. In this mode configuration registers can only be read (except MODE(1:0) register, which is always write accessible). Figure 24 shows the interface to memory structure.

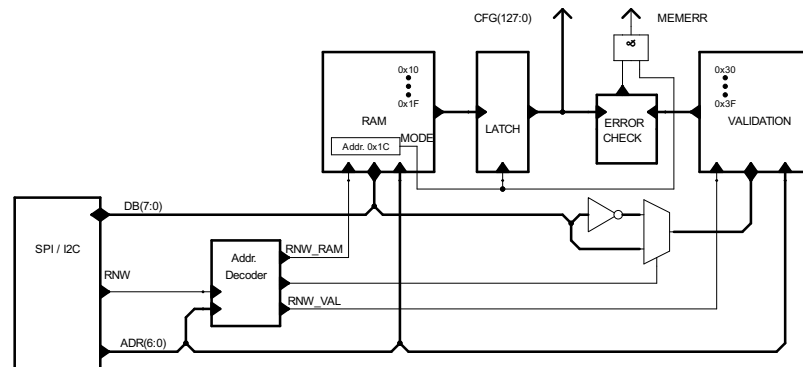

iC-HT

DUAL CW LASER DIODE DRIVER

Rev C1, Page 35/46

Figure 24: Interface, RAM integrity monitoring and configuration latching

Register map description

The register map consists of 64 addresses subdivided in three different pages:

- Read-only page, address 0x00 to 0x0F: iC-HT status, ADC readouts, thermometer readout and chip revision.
- Configuration page (integrity monitored), read-write registers, address 0x10 to 0x1F.
- Validation page, read-write registers, address 0x30 to 0x3F.

Read-only registers

Read-only registers are sub-divided as well into status registers (address 0x00 to 0x01) and measurement registers. Status registers are normally latched to 1 on events and cleared on read (see individual register description). Measurement registers are dual-port and can be accessed simultaneously with the measurements in progress. ADC1 (address 0x03 to 0x04) and ADC2 (address 0x05 to 0x06) are 10 bit registers split into two 8 bit registers each and must be accessed in block mode (automatic address increment) to ensure data not changing during the read.

Configuration page (integrity monitored)

The configuration page (address 0x10 to 0x1F) contains the registers that control the driver. Every write operation to any of the registers of this page will be internally duplicated to the correspondent register at the validation page. After the write operation, the correspondent validation register will contain the inverted value of the configuration register.

Validation page

The validation page (address 0x30 to 0x3F) can be read or written normally. Only when a write procedure is made to any of the configuration registers the correspondent validation pair will be written with the inverted value of the configuration register as well.

Both the configuration and validation pages are initialized during power-up. This event is signaled at the STATUS0 register (bit 0, INITRAM). In standby mode (NSTBY = lo) the RAM is not reset if any write command has been executed and therefore, configuration and validation pages keep the stored information and INITRAM remains unset. Entering standby mode after power-up without any write command, the RAM will be initialized again and the INITRAM bit will be set to 1 again. Any VDD power-down event signaled at the STATUS0 register outside the standby mode (NSTBY = hi) requires a RAM content check regardless of the state of the INITRAM bit to ensure data is not corrupted.

Possible start-up sequence:

1. iC-HT starts in operation mode with default configuration. INITRAM and PDOVDD error bits must be set in STATUS0, DISC1 (address 0x10, bit 3) and DISC2 (address 0x15, bit 3) are set to 1.
2. Write MODE(1:0) = "10" register (Addr. 0x1C) to enable the configuration mode.
3. Configure the laser channels.
4. Read back to verify a correct data transfer.
5. Set the DISC1, DISC2 bits to 0 on used channels.
6. Read the status registers (address 0x00, 0x01, 0x02) to detect possible errors and validate status. If any error exist, read again to ensure its validation.
7. Write MODE(1:0) = "01" register (address 0x1C) to apply the configuration and enable the memory integrity check.
8. During operation: monitor the status registers checking for errors. The NCHK pin signals any set status bit if not masked. This pin can be used to trigger an microcontroller interrupt line.

iC-HT DUAL CW LASER DIODE DRIVER

Rev C1, Page 36/46

START-UP

Setting pin NSTBY to lo iC-HT enters standby mode. In stand by mode and with no supply voltage at pin VDD and the current consumption on VB is reduced to less than 10 μ A (cf. *Electrical Characteristics No. 002*).

After wake-up (pin NSTBY rising edge), the internal regulated supply VDD is generated again. The required time T_{vdd} depends on the capacitor connected to pin VDD (cf. *Electrical Characteristics No. 504*).

Once the VDD voltage level is correct, iC-HT enters an offset compensation procedure regardless of the state of the laser enable pins (EC1, EC2). During this

time (T_{en}), EC1 and EC2 are ignored and laser cannot be switched on (cf. *Electrical Characteristics No. 111*). After this time (T_{en}), laser channels can be switched on.

The switch-on procedure needs an initial time (T_{ci}) to reach the 80% of the target light power (in APC mode) or laser current (in ACC mode) (cf. *Electrical Characteristics No. 112*) and an additional time (T_{cio}) to reach the 99% of the value (cf. *Electrical Characteristics No. 113*). Figure 25 illustrates an startup example for channel 1 in iC-WK mode.

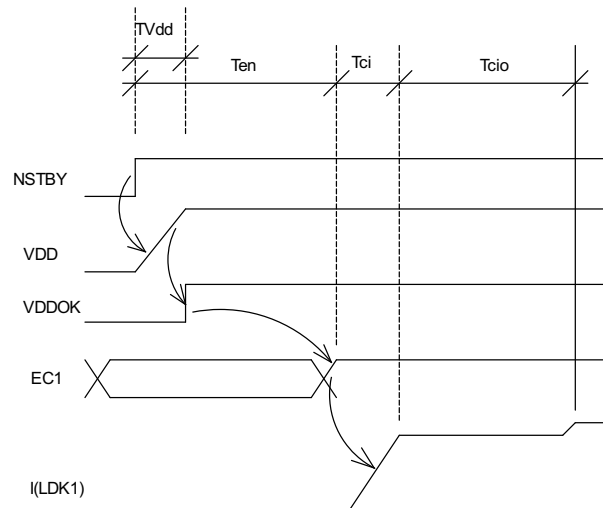

Figure 25: Startup timing diagram

iC-HT DUAL CW LASER DIODE DRIVER

Rev C1, Page 37/46

REGISTER OVERVIEW

OVERVIEW									
Addr	Bit 7	Bit 6	Bit 5	Bit 4	Bit 3	Bit 2	Bit 1	Bit 0	
0x00 R	CFGTIMO	OSCERR	OVC1	OVC2	OVT	MEMERR	PDOVDD	INITRAM	
0x01 R		LDKSAT2	MONC2	MAPC2		LDKSAT1	MONC1	MAPC1	
0x02 R	TEMP(7:0)								
0x03 R							ADC1(9:8)		
0x04 R	ADC1(7:0)								
0x05 R							ADC2(9:8)		
0x06 R	ADC2(7:0)								
0x07 R	Not implemented								
...	Not implemented								
0x0F R	Chip revision mark								
0x10	ADCC1(2:0)			EOC1	DISC1	DISP1	ECIE1	EACC1	
0x11	ILIM1(7:0)								
0x12	RMD1(7:0)								
0x13	COMP1(2:0)				RLDKS1(1:0)		REF1(9:8)		
0x14	REF1(7:0)								
0x15	ADCC2(2:0)			EOC2	DISC2	DISP2	ECIE2	EACC2	
0x16	ILIM2(7:0)								
0x17	RMD2(7:0)								
0x18	COMP2(2:0)				RLDKS2(1:0)		REF2(9:8)		
0x19	REF2(7:0)								
0x1A		ADSNF2		RACC2		ADSNF1		RACC1	
0x1B		MERGE	RDCO(5:0)						
0x1C	Not implemented						MODE(1:0)		
0x1D	SOSCERR	SOVC2	SOVC1	SOVT	MLDKSAT2	MLDKSAT1	MMONC	MOSCERR	
0x1E	Reserved register. Set to zero								
0x1F	Reserved register(Factory test). Set to zero								
0x20	Not implemented								
...	Not implemented								
0x30	Validation content for 0x10, inverted								
0x31	Validation content for 0x11, inverted								
...	...								
0x3F	Validation content for 0x1F, inverted								

Table 66: Register layout

iC-HT

DUAL CW LASER DIODE DRIVER

Rev C1, Page 38/46

PARAMETERS

Register	Address	Bits	Default	Description
ADCC1	0x10	7:5	000	Configuration for ADC from channel 1
ADCC2	0x15	7:5	000	Configuration for ADC from channel 2
ADSNF1	0x1A	2	0	MDA force/sense for ADC measurement in channel 1
ADSNF2	0x1A	6	0	MDA force/sense for ADC measurement in channel 2
RACC1	0x1A	0	0	Channel 1 ACC resistor mirror factor
RACC2	0x1A	4	0	Channel 2 ACC resistor mirror factor
COMP1	0x13	6:4	011	Channel 1 regulator delay compensation
COMP2	0x18	6:4	011	Channel 2 regulator delay compensation
DISC1	0x10	3	1	Software disable for channel 1
DISC2	0x15	3	1	Software disable for channel 2
DISP1	0x10	2	0	Disable PLR for channel 1
DISP2	0x15	2	0	Disable PLR for channel 2
EACC1	0x10	0	0	Enable ACC mode for channel 1
EACC2	0x15	0	0	Enable ACC mode for channel 2
ECIE1	0x10	1	0	Enable external CI capacitor for channel 1
ECIE2	0x15	1	0	Enable external CI capacitor for channel 2
EOC1	0x10	4	1	Enable offset compensation for channel 1
EOC2	0x15	4	1	Enable offset compensation for channel 2
ILIM1	0x11	7:0	0xFF	Current limit at channel 1
ILIM2	0x16	7:0	0xFF	Current limit at channel 2
MERGE	0x1B	6	0	MERGE channels 1 and 2, controlled by channel 1
MLDKSAT1	0x1D	2	1	LDKSAT1 error mask
MLDKSAT2	0x1D	3	1	LDKSAT2 error mask
MMONC	0x1D	1	1	MONC error mask
MODE	0x1C	1:0	01	Configuration / Operation mode selection
MOSCERR	0x1D	0	0	OSCERR error mask
RDCO	0x1B	5:0	0x02	DC converter set point
REF1	0x13/0x14	9:0	0x000	Voltage reference at channel 1
REF2	0x18/0x19	9:0	0x000	Voltage reference at channel 2
RLDKS1	0x13	3:2	00	Channel 1 LDK saturation detector threshold
RLDKS2	0x18	3:2	00	Channel 2 LDK saturation detector threshold
RMD1	0x12	7:0	0xFF	Resistor at channel 1
RMD2	0x17	7:0	0xFF	Resistor at channel 2
SOSCERR	0x1D	7	0	Oscillator error simulation (watchdog timeout)
SOVC1	0x1D	5	0	Overcurrent event at channel 1 simulation
SOVC2	0x1D	6	0	Overcurrent event at channel 2 simulation
SOVT	0x1D	4	0	Overtemperature event simulation
Reserved	0x1A	7:0	0x00	Reserved
Reserved	0x1F	7:0	0x00	Reserved

Table 67: Parameter overview

iC-HT DUAL CW LASER DIODE DRIVER

Rev C1, Page 39/46

Register	Address	Bits	Default	Description
INITRAM	0x00	0	R/O	RAM initialized.
PDOVDD	0x00	1	R/O	Power-down event at VDD
MEMERR	0x00	2	R/O	RAM memory validation error
OVT	0x00	3	R/O	Overtemperature event
OVC2	0x00	4	R/O	Overcurrent at channel 2
OVC1	0x00	5	R/O	Overcurrent at channel 1
OSCERR	0x00	6	R/O	Oscillator error (watchdog set)
CFGTIMO	0x00	7	R/O	Configuration mode timeout event
MAPC1	0x01	0	R/O	Channel 1 current state
MONC1	0x01	1	R/O	Monitor channel 1 enabled at least once (latched)
LDKSAT1	0x01	2	R/O	Channel 1 LDK saturation event
MAPC2	0x01	4	R/O	Channel 2 current state
MONC2	0x01	5	R/O	Monitor channel 2 enabled at least once (latched)
LDKSAT2	0x01	6	R/O	Channel 2 LDK saturation event

Table 68: Status overview

Register	Address	Bits	Default	Description
TEMP	0x02	7:0	R/O	Chip temperature measurement
ADC1h	0x03	1:0	R/O	Channel 1 ADC 9:8 readout
ADC1l	0x04	7:0	R/O	Channel 1 ADC 7:0 readout
ADC2h	0x05	1:0	R/O	Channel 2 ADC 9:8 readout
ADC2l	0x06	7:0	R/O	Channel 2 ADC 7:0 readout
CHIPREV	0x0F	7:0	R/O	Chip revision identification

Table 69: Measurement overview

Device identification

CHIPREV		Addr. 0x0F; bit 7:0	R
Code	Function		
0x00	Initial version iC-HT		
0x01	iC-HT_1		
0x02	iC-HT_Z		
0x08	Reserved		

Table 70: Device identification

Status

INITRAM		Addr. 0x00; bit 0	R
Code	Function		
0	RAM not initialized since last read		
1	RAM initialized. Cleared on read		

Table 71: RAM initialization

PDOVDD		Addr. 0x00; bit 1	R
Code	Function		
0	VDD power down not occurred since last read		
1	VDD power down event has occurred. Cleared on read		

Table 72: VDD power down

MEMERR		Addr. 0x00; bit 2	R
Code	Function		
0	RAM has not been changed since last validation		
1	RAM has changed and has not been validated		

Table 73: Memory validation

OVT		Addr. 0x00; bit 3	R
Code	Function		
0	No overtemperature event has occurred since last read		
1	Overtemperature event has occurred. Cleared on read		

Table 74: Overtemperature

iC-HT DUAL CW LASER DIODE DRIVER

Rev C1, Page 40/46

OVC2		Addr. 0x00; bit 4	R
Code	Function		
0	No overcurrent event at channel 2 has occurred since last read		
1	Overcurrent event at channel 2 has occurred. Cleared on read		

Table 75: Overcurrent channel 2

OVC1		Addr. 0x00; bit 5	R
Code	Function		
0	No overcurrent event at channel 1 has occurred since last read		
1	Overcurrent event at channel 1 has occurred. Cleared on read		

Table 76: Overcurrent channel 1

OSCERR		Addr. 0x00; bit 6	R
Code	Function		
0	Oscillator functioning OK		
1	Watchdog timeout set on oscillator failure.		

Table 77: Oscillator watchdog

CFGTIMO		Addr. 0x00; bit 7	R
Code	Function		
0	iC-HT not in <i>Configuration Mode</i> or <i>Timeout</i> did not happened till now		
1	iC-HT in <i>Configuration Mode</i> and <i>Timeout</i> happened. Laser switched off.		

Table 78: Configuration timeout

MAPC1		Addr. 0x01; bit 0	R
Code	Function		
0	Channel 1 is off at the precise reading moment		
1	Channel 1 is on at the precise reading moment		

Table 79: EC1 pin state

MONC1		Addr. 0x01; bit 1	R
Code	Function		
0	Channel 1 has not been switched on since last read		
1	Channel 1 has been switched on at least once. Cleared on read		

Table 80: Monitor channel 1

LDKSAT1		Addr. 0x01; bit 2	R
Code	Function		
0	Channel 1 LDK saturation voltage not reached.		
1	Channel 1 LDK saturation voltage reached at least once, cleared on read		

Table 81: LDK1 saturation

MAPC2		Addr. 0x01; bit 4	R
Code	Function		
0	Channel 1 is off at the precise reading moment		
1	Channel 1 is on at the precise reading moment		

Table 82: EC2 pin state

MONC2		Addr. 0x01; bit 5	R
Code	Function		
0	Channel 2 has not been switched on since last read		
1	Channel 2 has not been switched on since last read		

Table 83: Monitor channel 2

LDKSAT2		Addr. 0x01; bit 6	R
Code	Function		
0	Channel 2 LDK saturation voltage not reached.		
1	Channel 2 LDK saturation voltage reached at least once, Cleared on read		

Table 84: LDK2 saturation

Measurement registers

TEMP		Addr. 0x02; bit 7:0	R
Code	Function		
0x00	Minimum temperature		
0xFF	Maximum temperature		

Table 85: Chip temperature

ADC1		Addr. 0x03/04; bit 9:0	R
Code	Function		
0x000	ADC minimum value		
0x3FF	ADC maximum value		

Table 86: ADC channel 1

ADC2		Addr. 0x05/06; bit 9:0	R
Code	Function		
0x000	ADC minimum value		
0x3FF	ADC maximum value		

Table 87: ADC channel 2

iC-HT DUAL CW LASER DIODE DRIVER

Rev C1, Page 41/46

Channel 1 configuration registers

EACC1		Addr. 0x10; bit 0	R/W 0
Code	Function		
0	APC mode enabled for channel 1 (light power regulation)		
1	ACC mode enabled for channel 1 (laser current regulation)		

Table 88: Enable APC/ACC channel 1

ECIE1		Addr. 0x10; bit 1	R/W 0
Code	Function		
0	External CI capacitor for channel 1 disconnected		
1	External CI capacitor for channel 1 connected		

Table 89: Enable external CI capacitor channel 1

DISP1		Addr. 0x10; bit 2	R/W 0
Code	Function		
0	PLR enabled for channel 1		
1	PLR disabled for channel 1		

Table 90: Disable PLR channel 1

DISC1		Addr. 0x10; bit 3	R/W 1
Code	Function		
0	Channel 1 can be enabled by EC1 pin		
1	Channel 1 cannot be enabled by EC1 pin		

Table 91: Disable channel 1

EOC1		Addr. 0x10; bit 4	R/W 1
Code	Function		
0	Channel 1 regulator offset compensation disabled		
1	Channel 1 regulator offset compensation enabled		

Table 92: Enable offset compensation channel 1

ADCC1(2:0)		Addr. 0x10; bit 7:5	R/W 000
Code	Function		
0xx	Channel 1 ADC disabled		
100	Channel 1 ADC sourced by V(MDA1), ADSNF1 = 0		
100	Channel 1 ADC sourced by V(PLR1), ADSNF1 = 1		
101	Channel 1 ADC sourced by V(VB)		
110	Channel 1 ADC sourced by V(VDD)		
111	Channel 1 ADC sourced by V(LDK1)		

Table 93: ADC source selection channel 1

ILIM1		Addr. 0x11; bit 7:0	R/W 0xFF
Code	Function		
0x0A	Channel 1 overcurrent threshold set to the minimum current		
...	Channel 1 overcurrent threshold set to $I_{lim} = (\Delta I(LDK) \cdot n)$, n from 10 to 255		
0xFF	Channel 1 overcurrent threshold set to the maximum current		

Table 94: Overcurrent threshold configuration channel 1

RMD1		Addr. 0x12; bit 7:0	R/W 0xFF
Code	Function		
0x00	PLR1 set to the minimum resistance		
...	PLR1 resistor set to $Rmd = Rmd_0(1 + \frac{\Delta Rmd(\%)}{100})^{n+1}$, n from 0 to 255		
0xFF	PLR1 resistor set to the maximum resistance		

Table 95: MDA resistor channel 1

COMP1		Addr. 0x13; bit 6:4	R/W 011
Code	Function		
000	Minimum regulator delay compensation for channel 1, slower response		
...			
111	Maximum regulator delay compensation for channel 1, faster response		

Table 96: Regulator delay compensation channel 1

RLDKS1		Addr. 0x13; bit 3:2	R/W 00
Code	Function		
00	V(LDK1) < 0.5 V sets the LDKSAT1 alarm bit		
01	V(LDK1) < 0.8 V sets the LDKSAT1 alarm bit		
10	V(LDK1) < 1.0 V sets the LDKSAT1 alarm bit		
11	V(LDK1) < 1.2 V sets the LDKSAT1 alarm bit		

Table 97: LDK saturation threshold selection channel 1

REF1		Addr. 0x13/14; bit 9:0	R/W 0x000
Code	Function		
0x000	Channel 1 regulator reference voltage set to minimum voltage		
...	Channel 1 regulator reference voltage set to $Vref = Vref_0(1 + \frac{\Delta Vref(\%)}{100})^{n+1}$, n from 0 to 1023		
0x3FF	Channel 1 regulator reference voltage set to maximum voltage		

Table 98: Regulator voltage reference channel 1

RACC1		Addr. 0x1A; bit 0	R/W 0
Code	Function		
0	Current range high for channel 1		
1	Current range low for channel 1		

Table 99: Current range configuration channel 1

iC-HT DUAL CW LASER DIODE DRIVER

Rev C1, Page 42/46

ADSNF1		Addr. 0x1A; bit 2	R/W 0
Code	Function		
0	ADC measurement MDA1 pad (force)		
1	ADC measurement PLR1 (sense)		

Table 100: ADC channel 1 sense/force selection

ADCC2(2:0)		Addr. 0x15; bit 7:5	R/W 000
Code	Function		
0xx	Channel 2 ADC disabled		
100	Channel 2 ADC sourced by V(MDA2), ADSNF2 = 0		
101	Channel 2 ADC sourced by V(PLR2), ADSNF2 = 1		
110	Channel 2 ADC sourced by V(VB)		
111	Channel 2 ADC sourced by V(LDK2)		

Table 106: ADC source selection channel 2

Channel 2 configuration registers

EACC2		Addr. 0x15; bit 0	R/W 0
Code	Function		
0	APC mode enabled for channel 2 (light power regulation)		
1	ACC mode enabled for channel 2 (laser current regulation)		

Table 101: Enable APC/ACC channel 2

ILIM2		Addr. 0x16; bit 7:0	R/W 0xFF
Code	Function		
0x0A	Channel 2 overcurrent threshold set to the minimum current		
...	Channel 2 overcurrent threshold set to $I_{lim} = (\Delta I(LDK) \cdot n)$, n from 10 to 255		
0xFF	Channel 2 overcurrent threshold set to the maximum current		

Table 107: Overcurrent threshold configuration channel 2

ECIE2		Addr. 0x15; bit 1	R/W 0
Code	Function		
0	External CI capacitor for channel 2 disconnected		
1	External CI capacitor for channel 2 connected		

Table 102: Enable external CI capacitor channel 2

RMD2		Addr. 0x17; bit 7:0	R/W 0xFF
Code	Function		
0x00	PLR2 resistor set to the minimum resistance		
...	PLR2 resistor set to $Rmd = Rmd_0(1 + \frac{\Delta Rmd(\%)}{100})^{n+1}$, n from 0 to 255		
0xFF	PLR2 resistor set to the maximum resistance		

Table 108: MDA resistor channel 2

DISP2		Addr. 0x15; bit 2	R/W 0
Code	Function		
0	Internal resistor at MDA2 enabled for channel 2		
1	Internal resistor at MDA2 disabled for channel 2		

Table 103: Disable PLR channel 2

COMP2		Addr. 0x18; bit 6:4	R/W 011
Code	Function		
000	Minimum regulator delay compensation for channel 2, slower response		
...			
111	Maximum regulator delay compensation for channel 2, faster response		

Table 109: Regulator delay compensation channel 2

DISC2		Addr. 0x15; bit 3	R/W 1
Code	Function		
0	Channel 2 can be enabled by EC2 pin		
1	Channel 2 cannot be enabled by EC2 pin		

Table 104: Disable channel 2

RLDKS2		Addr. 0x18; bit 3:2	R/W 00
Code	Function		
00	V(LDK2) < 0.5 V sets the LDKSAT2 alarm bit		
01	V(LDK2) < 0.8 V sets the LDKSAT2 alarm bit		
10	V(LDK2) < 1.0 V sets the LDKSAT2 alarm bit		
11	V(LDK2) < 1.2 V sets the LDKSAT2 alarm bit		

Table 110: LDK saturation threshold selection channel 2

EOC2		Addr. 0x15; bit 4	R/W 1
Code	Function		
0	Channel 2 regulator offset compensation disabled		
1	Channel 2 regulator offset compensation enabled		

Table 105: Enable offset compensation channel 2

IC-HT DUAL CW LASER DIODE DRIVER

Rev C1, Page 43/46

REF2		Addr. 0x18/19; bit 9:0	R/W 0x000
Code	Function		
0x000	Channel 2 regulator reference voltage set to minimum voltage		
...	Channel 2 regulator reference voltage set to $V_{ref} = V_{ref0}(1 + \frac{\Delta V_{ref}(\%)}{100})^{n+1}$, n from 0 to 1023		
0x3FF	Channel 2 regulator reference voltage set to maximum voltage		

Table 111: Regulator voltage reference channel 2

RACC2		Addr. 0x1A; bit 4	R/W 0
Code	Function		
0	Current range high for channel 2		
1	Current range low for channel 2		

Table 112: Current range configuration channel 2

ADSNF2		Addr. 0x1A; bit 6	R/W 0
Code	Function		
0	ADC measurement MDA2 pad (force)		
1	ADC measurement PLR2 (sense)		

Table 113: ADC channel 2 sense/force selection

General configuration registers

RDCO		Addr. 0x1B; bit 5:0	R/W 0x02
Code	Function		
0x00	No current		
...			
0x3F	140 μ A Typ (see spec point D01)		

Table 114: DCO current control

MMONC		Addr. 0x1D; bit 1	R/W 1
Code	Function		
0	MONC1 and MONC2 event will be signaled at NCHK		
1	MONC1 and MONC2 event will not be signaled at NCHK		

Table 118: Monitor channel 1 and 2 event mask

MERGE		Addr. 0x1B; bit 6	R/W 0
Code	Function		
0	Channel 1 and 2 operate independently		
1	Power transistor from channel 2 usable in parallel with channel 1, regulation made by channel 1.		

Table 115: Channel combination

MLDKSAT1		Addr. 0x1D; bit 2	R/W 1
Code	Function		
0	LDKSAT1 event will be signaled at NCHK		
1	LDKSAT1 event will not be signaled at NCHK		

Table 119: LDK saturation error mask channel 1

MODE(1:0)		Addr. 0x1C; bit 1:0	R/W 01
Code	Function		
00	Not allowed, signaled as memory error		
01	Chip set in operation mode (apply configuration, latch transparent)		
10	Chip set in configuration mode (hold previous configuration)		
11	Not allowed, signaled as memory error		

Table 116: Configuration and operation mode

MLDKSAT2		Addr. 0x1D; bit 3	R/W 1
Code	Function		
0	LDKSAT2 event will be signaled at NCHK		
1	LDKSAT2 event will not be signaled at NCHK		

Table 120: LDK saturation error mask channel 2

SOVT		Addr. 0x1D; bit 4	R/W 0
Code	Function		
0	No overtemperature event is simulated.		
1	Overtemperature event simulated.		

Table 121: Simulate overtemperature

MOSCERR		Addr. 0x1D; bit 0	R/W 0
Code	Function		
0	Oscillator error (watchdog) will be signaled at NCHK		
1	Oscillator error (watchdog) will not be signaled at NCHK		

Table 117: Oscillator watchdog error mask

SOVC1		Addr. 0x1D; bit 5	R/W 0
Code	Function		
0	No Overcurrent event at channel 1 is simulated.		
1	Overcurrent event at channel 1 simulated.		

Table 122: Simulate overcurrent channel 1

iC-HT DUAL CW LASER DIODE DRIVER

Rev C1, Page 44/46

SOVC2		Addr. 0x1D; bit 6	R/W 0
Code	Function		
0	No overcurrent event at channel 2 is simulated.		
1	Overcurrent event at channel 2 simulated.		

Table 123: Simulate overcurrent channel 2

SOSCERR		Addr. 0x1D; bit 7	R/W 0
Code	Function		
0	No oscillator error simulated.		
1	Oscillator error simulated (watchdog timeout).		

Table 124: Simulate oscillator error

DESIGN REVIEW: Notes On Chip Functions

iC-HT 0, 1		
No.	Function, Parameter/Code	Description and Application Notes
1	Adr. 0x1A	Reserved, Adr. 0x1A Should be always zero
2	CHIPREV	For iC-HT chip releases see Table 70.

Table 125: Notes on chip functions regarding iC-HT chip release 0 and 1.

iC-HT Z		
No.	Function, Parameter/Code	Description and Application Notes
1	ADSNF1,ADSNF2	Adr. 0x1A bits 2, 6 new implemented. See page nr. 28
2	RACC1,RACC2	Adr. 0x1A bits 0, 4 new implemented. See page nr. 17
3	CHIPREV	For iC-HT chip releases see Table 70.

Table 126: Notes on chip functions regarding iC-HT chip release Z

REVISION HISTORY

Rel.	Rel. Date*	Chapter	Modification	Page
A1	13-02-22		Initial Release.	

Rel.	Rel. Date*	Chapter	Modification	Page
B1	15-02-09	ELECTRICAL CHARACTERISTICS	Item 001: VB max updated from 8V to 11V.	6
		ELECTRICAL CHARACTERISTICS	Item 107: Laser overcurrent shutdown threshold updated from 93mA to 80mA	6
		ELECTRICAL CHARACTERISTICS	Item 108: Shutdown threshold resolution updated from 3 mA to 5 mA Item 108: Shutdown threshold resolution updated from 0.3 mA to 0.5 mA	6
		ELECTRICAL CHARACTERISTICS	Item 114: LDKx ACC mode current updated from 60 mA to 50 mA Item 114: LDKx ACC mode current updated from 750 mA to 650 mA Item 114: LDKx ACC mode current updated typical from 905 mA to 750 mA	7
		ELECTRICAL CHARACTERISTICS	Item 115: added TK -1500 ppm/K min, -500 ppm/K typ., 0 ppm/K max	7
		ELECTRICAL CHARACTERISTICS	Item 302: Percentual voltage increments updated from 0.05% to 0.1%	7
		ELECTRICAL CHARACTERISTICS	Item 403: Leakage Current at NCHK updated from ±10 to ±1	7
		ELECTRICAL CHARACTERISTICS	Item 602: Input Threshold Voltage at 2.8V updated from 0.7V to 0.6V	7
		ELECTRICAL CHARACTERISTICS	Item B02: Overtemperature Release updated from 160 °C to 165 °C	8
		OPERATING AND STANDBY MODES	EMC and INS open pin description updated Web link to iC-WK iC-WKL updated	10
		MICROCONTROLLER MODE	MAPCx description updated Figure 10 updated with more details	20
		COMBINING BOTH CHANNELS	ILIM1 and REF1 tables added	22
		SERIAL COMMUNICATION INTERFACES	Figure 14: I ² C frames updated	24

iC-HT DUAL CW LASER DIODE DRIVER

Rev C1, Page 45/46

	PARAMETERS	Table 81: MAPC1 description updated Table 84: MAPC2 description updated	40
	PARAMETERS	Table 114: RACC2 updated	42
	PARAMETERS	Table 120: MMONC description updated	43

Rel.	Rel. Date*	Chapter	Modification	Page
C1		BLOCK DIAGRAM	Updated	1
		ELECTRICAL CHARACTERISTICS	Items 004, 005, 007, 008 updated	6
		ELECTRICAL CHARACTERISTICS	Items 601, 602, 603: Parameters updated	7
		iC-WK MODE	Figure 6 new	13
		MICROCONTROLLER MODE	Description updated	16
		MICROCONTROLLER MODE	Figure 11 updated	21
		MICROCONTROLLER MODE	Figure 12 new	21
		SERIAL COMMUNICATION INTERFACES	Figure 16 updated	24
		8 BIT INTERNAL PROGRAMMABLE LOGARITHMIC MONITOR RESISTORS	Figure 17 new	26
		10 BIT LINEAR A/D CONVERTER	Description updated	28
		WATCHDOG TIMER	Table 57 updated	32
		DIGITAL INTERFACE AND MEMORY INTEGRITY MONITOR	Description updated	34
		PARAMETERS	Table 77 updated	40

iC-Haus expressly reserves the right to change its products, specifications and related supplements (together the Documents). A Datasheet Update Notification (DUN) gives details as to any amendments and additions made to the relevant Documents on our internet website www.ichaus.com/DUN and is automatically generated and shall be sent to registered users by email.
Copying – even as an excerpt – is only permitted with iC-Haus' approval in writing and precise reference to source.

The data and predicted functionality is intended solely for the purpose of product description and shall represent the usual quality and behaviour of the product. In case the Documents contain obvious mistakes e.g. in writing or calculation, iC-Haus reserves the right to correct the Documents and no liability arises insofar that the Documents were from a third party view obviously not reliable. There shall be no claims based on defects as to quality and behaviour in cases of insignificant deviations from the Documents or in case of only minor impairment of usability.
No representations or warranties, either expressed or implied, of merchantability, fitness for a particular purpose or of any other nature are made hereunder with respect to information/specification resp. Documents or the products to which information refers and no guarantee with respect to compliance to the intended use is given. In particular, this also applies to the stated possible applications or areas of applications of the product.

iC-Haus products are not designed for and must not be used in connection with any applications where the failure of such products would reasonably be expected to result in significant personal injury or death (*Safety-Critical Applications*) without iC-Haus' specific written consent. Safety-Critical Applications include, without limitation, life support devices and systems. iC-Haus products are not designed nor intended for use in military or aerospace applications or environments or in automotive applications unless specifically designated for such use by iC-Haus.
iC-Haus conveys no patent, copyright, mask work right or other trade mark right to this product. iC-Haus assumes no liability for any patent and/or other trade mark rights of a third party resulting from processing or handling of the product and/or any other use of the product.

Software and its documentation is provided by iC-Haus GmbH or contributors "AS IS" and is subject to the ZVEI General Conditions for the Supply of Products and Services with iC-Haus amendments and the ZVEI Software clause with iC-Haus amendments (www.ichaus.com/EULA).

* Release Date format: YYYY-MM-DD

iC-HT
DUAL CW LASER DIODE DRIVER

Rev C1, Page 46/46

ORDERING INFORMATION

Type	Package	Order Designation
iC-HT	QFN28 5 mm x 5 mm	iC-HT QFN28-5x5
Evaluation Board	100 mm x 80 mm eval board	iC-HT EVAL HT1D

Please send your purchase orders to our order handling team.

For technical support, information about prices and terms of delivery please contact us.